

།། འཕུལ་རྒྱལ་འཛིན་གཙུག་ལག་སློབ་མཉམས།།
།། ཚེ་རིག་དང་འཕུལ་རིག་མཐོ་རིམ་སློབ་གྲྭ།།

Royal University of Bhutan
College of Science and Technology
Rinchending: Bhutan



Bidding Documents for the PKG-06 Supply of Library Furniture



Table of Contents

PART 1 – Bidding Procedures.....	3
<i>Section I. Instructions to Bidders.....</i>	<i>3</i>
<i>Table of Clauses.....</i>	<i>4</i>
<i>Section II. Bid Data Sheet.....</i>	<i>26</i>
<i>Section III. Evaluation and Qualification Criteria.....</i>	<i>29</i>
<i>Section IV. Bidding Forms.....</i>	<i>33</i>
<i>Table of Forms.....</i>	<i>33</i>
PART 2 – Supply Requirements	42
<i>Section VI: Schedule of Supply.....</i>	<i>43</i>
<i>Contents.....</i>	<i>43</i>
<i>Section VII. General Conditions of Contract.....</i>	<i>50</i>
<i>Table of Clauses.....</i>	<i>50</i>
<i>Section VIII. Special Conditions of Contract.....</i>	<i>68</i>
<i>Section IX. Contract Forms.....</i>	<i>75</i>
<i>Table of Forms.....</i>	<i>75</i>
<i>Contract Agreement.....</i>	<i>76</i>
<i>Performance Security.....</i>	<i>81</i>
<i>Bank Guarantee for Advance Payment.....</i>	<i>82</i>



PART 1 – Bidding Procedures

Section I. Instructions to Bidders



Table of Clauses

A. General.....	6
1. <i>Scope of Bid</i>	6
2. <i>Fraud and Corruption</i>	6
3. <i>Eligible Bidders</i>	7
4. <i>Exclusion of Bidders</i>	8
5. <i>Eligible Goods and Related Services</i>	9
B. Contents of Bidding Documents.....	9
6. <i>Parts of Bidding Documents</i>	9
7. <i>General Information</i>	10
8. <i>Clarification of Bidding Documents</i>	10
9. <i>Amendment of Bidding Documents</i>	10
C. Preparation of Bids.....	10
10. <i>Cost of Bidding</i>	10
11. <i>Language of Bid</i>	11
12. <i>Documents Comprising the Bid</i>	11
13. <i>Bid Submission Sheet</i>	11
14. <i>Price Schedules</i>	12
15. <i>Alternative Bids</i>	12
16. <i>Bid Prices and Discounts</i>	12
17. <i>Price Variation</i>	13
18. <i>Currencies of Bid</i>	13
19. <i>Documents Establishing the Eligibility of the Bidder</i>	14
20. <i>Documents Establishing the Eligibility of the Goods and Related Services</i>	14
21. <i>Documents Establishing the Conformity of the Goods and Related Services</i>	14
22. <i>Documents Establishing the Qualifications of the Bidder</i>	14
23. <i>Period of Validity of Bids</i>	15
24. <i>Bid Security</i>	15
25. <i>Format and Signing of Bid</i>	16
D. Submission and Opening of Bids.....	17
26. <i>Submission, Sealing and Marking of Bids</i>	17
27. <i>Deadline for Submission of Bids</i>	17
28. <i>Late Bids</i>	18
29. <i>Withdrawal, Substitution and Modification of Bids</i>	18



30. Bid Opening	18
E. Evaluation and Comparison of Bids	20
31. Confidentiality	20
32. Clarification of Bids.....	20
33. Responsiveness of Bids	20
34. Nonconformities, Errors and Omissions.....	21
35. Preliminary Examination of Bids.....	21
36. Examination of Terms and Conditions; Technical Evaluation.....	22
37. Conversion to Single Currency.....	22
38. Margin of Preference	22
39. Evaluation of Bids.....	22
40. Comparison of Bids.....	23
41. Postqualification of the Bidder	23
42. Purchaser's Right to Accept Any Bid, and to Reject Any or All Bids	24
F. Award of Contract	24
43. Award Criteria.....	24
44. Purchaser's Right to Vary Quantities at Time of Award.....	24
45. Notification of Award.....	24
46. Signing of Contract.....	25
47. Performance Security.....	25



Section I. Instructions to Bidders

A. General	
1	Scope of Bid
1.1	The Purchaser, as indicated in the Bid Data Sheet (BDS), issues these Bidding Documents for the supply of Goods and Related Services incidental thereto as specified in Section VI, Schedule of Supply. The name, identification number, and number of lots within this procurement are provided in the BDS
1.2	Throughout these Bidding Documents: <ul style="list-style-type: none"> (a) the term “in writing” means communicated in written form (eg by mail, electronic mail, fax, telex) with proof of receipt; (b) if the context so requires, “singular” means plural” and vice versa; and (c) “day” means calendar day.
2	Fraud and Corruption
2.1	It is RGoB policy to require that Purchasers, Bidders, Suppliers, Contractors and their Subcontractors observe the highest standards of ethics during the procurement and execution of contracts. ¹ In pursuance of this policy, the RGoB: <ul style="list-style-type: none"> (a) defines, for the purposes of this provision, the terms set forth below as follows: <ul style="list-style-type: none"> (i) “Corrupt practice”² is the offering, giving, receiving or soliciting, directly or indirectly, of anything of value³ to influence improperly the actions of another party; (ii) “Fraudulent practice”⁴ is any intentional act or omission, including a misrepresentation, that knowingly or recklessly misleads, or attempts to mislead, a party to obtain a financial or other benefit or to avoid an obligation; (iii) “Collusive practice”⁵ is an arrangement between two or more parties designed to achieve an improper purpose, including to influence improperly the actions of another party; (iv) “Coercive practice”⁶ is impairing or harming, or threatening to impair or harm,

¹ In this context, any action taken by a Bidder, Supplier, Contractor or a Subcontractor to influence the procurement process or contract execution for undue advantage is improper.

² “another party” refers to a public official acting in relation to the procurement process or contract execution. In this context, “public official” includes staff and employees of any organizations (including any institutions providing finance for the Goods) taking or reviewing procurement decisions.

³ “anything of value” includes, but is not limited to, any gift, loan, fee, commission, valuable security or other asset or interest in an asset; any office, employment or contract; any payment, discharge or liquidation of any loan, obligation or other liability whatsoever, whether in whole or in part; any other services, favour or advantage, including protection from any penalty or disability incurred or apprehended or from any action or proceeding of a disciplinary or penal nature, whether or not already instituted and including the exercise or the forbearance from the exercise of any right or any official power or duty.

⁴ a “party” refers to a public official; the terms “benefit” and “obligation” relate to the procurement process or contract execution; and the “act or omission” is intended to influence the procurement process or contract execution.

⁵ “parties” refers to participants in the procurement process (including public officials) and an “improper purpose” includes attempting to establish bid prices at artificial, non competitive levels.



directly or indirectly, any party or the property of the party to influence improperly the actions of a party;

- (v) "Obstructive practice" is
- (aa) deliberately destroying, falsifying, altering or concealing of evidence material to the investigation or making false statements to investigators in order materially to impede any investigation into allegations of a corrupt, fraudulent, coercive or collusive practice; and/or threatening, harassing or intimidating any party to prevent it from disclosing its knowledge of matters relevant to the investigation or from pursuing the investigation; or
 - (bb) acts intended materially to impede the exercise of the inspection and audit rights of the Purchaser or any organization or person appointed by the Purchaser and/or any relevant RGoB agency provided for under ITB Sub-Clause 2.1 (d) below.
- (b) will reject a proposal for award if it determines that the Bidder recommended for award has, directly or through an agent, engaged in corrupt, fraudulent, collusive, coercive or obstructive practices in competing for the contract in question;
 - (c) will sanction a firm or individual, including declaring them ineligible, either indefinitely or for a stated period of time, to be awarded an RGoB-financed contract if it at any time determines that they have, directly or through an agent, engaged in corrupt, fraudulent, collusive, coercive or obstructive practices in competing for, or in executing, an RGoB-financed contract;
 - (d) will have the right to require that a provision be included in Bidding Documents and in contracts financed by the RGoB, requiring Bidders, Suppliers, Contractors and their Subcontractors to permit the Purchaser, any organization or person appointed by the Purchaser and/or any relevant RGoB agency to inspect their accounts and records and other documents relating to their Bid submission and contract performance and to have them audited by auditors appointed by the Purchaser;
 - (e) requires that Bidders, as a condition of admission to eligibility, execute and attach to their bids an Integrity Pact Statement in the form provided in Section IV, Bidding Forms as specified in the BDS. Failure to provide a duly executed Integrity Pact Statement may result in disqualification of the Bid; and
 - (f) will report any case of corrupt, fraudulent, collusive, coercive or obstructive practice to the relevant RGoB agencies, including but not limited to the Anti-corruption Commission (ACC) of Bhutan, for necessary action in accordance with the statutes and provisions of the relevant agency.

2.2 Furthermore, Bidders shall be aware of the provision stated in Sub-Clause 36.1 (a) (iii) of the General Conditions of Contract.

3 Eligible Bidders

3.1 ~~A Bidder, and all parties constituting the Bidder, may have the nationality of any country,~~

⁶ a "party" refers to a participant in the procurement process or contract execution.



~~subject to the restrictions specified in Section V, Eligible Countries.~~ A Bidder shall be deemed to have the nationality of a country if the Bidder is a citizen or is constituted, incorporated, or registered and operates in conformity with the provisions of the laws of that country. This criterion shall also apply to the determination of the nationality of proposed subcontractors or suppliers for any part of the Contract including Related Services.

- 3.2 A Bidder shall not have a conflict of interest. All Bidders found to have a conflict of interest shall be disqualified. Bidders may be considered to have a conflict of interest with one or more parties in this bidding process if they:
- (a) are associated, or have been associated in the past, with a firm or any of its affiliates which has been engaged by the Purchaser to provide consulting services for the preparation of the design, specifications and/or other documents to be used for the procurement of the Goods to be purchased pursuant to these Bidding Documents, or
 - (b) submit more than one Bid in this bidding process, except for alternative offers permitted under ITB Clause 15. However, this does not limit the participation of subcontractors in more than one Bid.
 - (c) employ or otherwise engage, either directly or through any of their affiliates, a spouse, dependent or close relative of a public servant of the RGoB who either is employed by the Purchaser or has an authority over it. For the purposes of this Sub-Clause a close relative is defined as immediate family which includes father, mother, brother, sister, spouse and own children.
- 3.3 Government-owned enterprises in Bhutan shall be eligible only if they can establish that they (i) are legally and financially autonomous, (ii) operate under commercial law, and (iii) are not a dependent agency (directly or indirectly) of the Purchaser.
- 3.4 A Bidder that is under a declaration of ineligibility pursuant to ITB Sub-Clause 2.1 (c) shall not be eligible to participate in this bidding process in any capacity.
- 3.5 Bidders shall provide such evidence of their continued eligibility satisfactory to the Purchaser as the Purchaser shall reasonably request.

4 Exclusion of Bidders

- 4.1 A Bidder shall be excluded from participating in this bidding process under the following circumstances:
- (a) as a matter of law or official regulation, RGoB prohibits commercial relations with the country in which the Bidder is constituted, incorporated or registered; or
 - (b) by an act of compliance with a decision of the United Nations Security Council taken under Chapter VII of the Charter of the United Nations, RGoB prohibits (i) any import of Goods or contracting of Services from the country in which the Bidder is constituted, incorporated or registered or (ii) any payments to persons or entities in that country; or
 - (c) he is insolvent or is in receivership or is a bankrupt or is in the process of being wound up; or has entered into an arrangement with creditors; or
 - (d) his affairs are being administered by a court, judicial officer or appointed liquidator; or
 - (e) he has suspended business or is in any analogous situation arising from similar procedures



<p>under the laws and regulations of his country of establishment; or</p> <p>(f) he has been found guilty of professional misconduct by a recognized tribunal or professional body; or</p> <p>(g) he has not fulfilled his obligations with regard to the payment of taxes, social security or other payments due in accordance with the laws of the country in which he is established or of the Kingdom of Bhutan; or</p> <p>(h) he is guilty of serious misrepresentation in supplying information in his tender; or</p> <p>(i) he has been convicted for fraud and/or corruption by a competent authority; or</p> <p>(j) he has not fulfilled any of his contractual obligations with the Purchaser in the past.</p> <p>(k) he has been debarred from participation in public procurement by any competent authority as per law.</p>
<p>5. Eligible Goods and Related Services</p> <p>5.1 All the Goods and Related Services to be supplied under the Contract may have their origin in any country in accordance with Section V, Eligible Countries.</p> <p>5.2 For the purposes of this Clause, the term “Goods” includes commodities, raw material, machinery, equipment and industrial plants; and “Related Services” includes services such as insurance, installation, training, and initial maintenance.</p> <p>5.3 The term “origin” means the country where the Goods have been mined, grown, cultivated, produced, manufactured or processed; or, through manufacture, processing, or assembly, another commercially recognized article results that differs substantially in its basic characteristics from its components.</p>
<p>B. Contents of Bidding Documents</p>
<p>6. Parts of Bidding Documents</p> <p>6.1 The Bidding Documents consist of Parts 1, 2 and 3, which include all the Sections indicated below, and should be read in conjunction with any Addenda issued in accordance with ITB Clause 9.</p>
<p>PART 1 Bidding Procedures</p> <ul style="list-style-type: none"> • Section I. Instructions to Bidders (ITB) • Section II. Bid Data Sheet (BDS) • Section III. Evaluation and Qualification Criteria • Section IV. Bidding Forms <p>PART 2 Supply Requirements</p> <ul style="list-style-type: none"> • Section VI. Schedule of Supply <p>PART 3 Contract</p>



<ul style="list-style-type: none"> • Section VII. General Conditions of Contract (GCC) • Section VIII. Special Conditions of Contract (SCC) • Section IX. Contract Forms
<p>7. General Information</p> <p>7.1 The Invitation for Bids issued by the Purchaser is not part of the Bidding Documents.</p> <p>7.2 The Purchaser is not responsible for the completeness of the Bidding Documents and their addenda, if any, if these were not obtained directly from the Purchaser.</p> <p>7.3 The Bidder is expected to examine all instructions, forms, terms and specifications in the Bidding Documents. Failure to furnish all information or documentation required by the Bidding Documents may result in the rejection of the Bid.</p>
<p>8. Clarification of Bidding Documents</p> <p>8.1 Bidders shall not be allowed to seek any clarification of the Bidding Documents in person or by telephone or other verbal means.</p> <p>8.2 A prospective Bidder requiring any clarification of the Bidding Documents shall notify the same to the Purchaser in writing at the Purchaser's address specified in the BDS;</p> <p>8.3 The Purchaser shall respond in writing to any such request for clarification, provided that it is received no later than fifteen (15) days prior to the deadline for submission of Bids. Copies of the Purchaser's response shall be forwarded to all those who have acquired the Bidding Documents directly from the Purchaser, including a description of the enquiry without disclosing the name of the Bidder(s) seeking clarification. Should the Purchaser deem it necessary to amend the Bidding Documents as a result of a clarification, it shall do so following the procedure under ITB Clause 9 and ITB Sub-Clause 27.2; and</p> <p>8.4 A pre-bid meeting shall be conducted only if strictly necessary to clarify doubts and concerns of the Bidders prior to submission of Bids. Minutes of the pre-bid meeting shall be circulated to all Bidders that have purchased Bidding Documents.</p>
<p>9. Amendment of Bidding Documents</p> <p>9.1 At any time prior to the deadline for submission of Bids the Purchaser may amend the Bidding Documents by issuing an addendum. This may be done either on the Purchaser's own initiative or in response to a clarification request from a prospective Bidder.</p> <p>9.2 Any addendum thus issued shall be part of the Bidding Documents and shall be communicated in writing to all who have obtained the Bidding Documents directly from the Purchaser. Such addendum shall be binding on the prospective Bidders, and shall require that prospective Bidders confirm receipt of it before the time established for the opening of Bids;</p> <p>9.3 The Purchaser may, at its discretion, extend the deadline for submission of Bids pursuant to ITB Sub-Clause 27.2 to allow prospective Bidders reasonable time in which to take the addendum into account in preparation of their Bids.</p>
<p>C. Preparation of Bids</p>
<p>10. Cost of Bidding</p>



10.1 The Bidder shall bear all costs associated with the preparation and submission of its Bid, and the Purchaser shall not be responsible or liable for those costs, regardless of the conduct or outcome of the Bidding process.

11. Language of Bid

11.1 The Bid, as well as all correspondence and documents relating to the Bid exchanged by the Bidder and the Purchaser, shall be written in the language specified in the BDS. Supporting documents and printed literature that are part of the Bid may be in another language provided they are accompanied by an accurate translation of the relevant passages in the language specified in the BDS, in which case, for the purposes of interpretation of the Bid, such translation shall govern.

12. Documents Comprising the Bid

12.1 The Bid shall comprise the following:

- (a) Bid Submission Sheet and the applicable Price Schedules in accordance with ITB Clauses 13, 14, 16 and 18;
- (b) Bid Security, in accordance with ITB Clause 24;
- (c) Written confirmation authorizing the signatory of the Bid to commit the Bidder, in accordance with ITB Clause 25;
- (d) Documentary evidence in accordance with ITB Clause 19 establishing the Bidder's eligibility to bid;
- (e) Documentary evidence in accordance with ITB Clause 20 that the Goods and Related Services to be supplied by the Bidder are of eligible origin;
- (f) Documentary evidence in accordance with ITB Clauses 21 and 33 that the Goods and Related Services conform to the Bidding Documents;
- (g) Documentary evidence in accordance with ITB Clause 22 establishing the Bidder's qualifications to perform the contract if its Bid is accepted;
- (h) Alternative Bids, if permissible, in accordance with ITB Clause 15;
- (i) Documentary evidence or certified statements that the Bidder is not in any of the exclusion categories stipulated in ITB Sub-Clause 4.1;
- (j) Integrity Pact Statement, in accordance with ITB Sub-Clause 2.1 (e) as specified in BDS; and
- (k) Any other document required in the BDS.

13. Bid Submission Sheet

13.1 The Bidder shall submit the Bid Submission Sheet using the form furnished in Section IV, Bidding Forms. This form must be completed without any alterations to its format, and no substitutes shall be accepted. All blank spaces shall be filled in with the information



requested.
14. Price Schedules
14.1 The Bidder shall submit the Price Schedules for Goods and Related Services, according to their origin as appropriate, using the forms furnished in Section IV, Bidding Forms.
15. Alternative Bids
15.1 Unless otherwise indicated in the BDS alternative Bids shall not be considered.
16. Bid Prices and Discounts
16.1 The prices and discounts quoted by the Bidder in the Bid Submission Sheet and in the Price Schedules shall conform to the requirements specified below.
16.2 All lots and items in the Schedule of Supply must be listed and priced separately in the Price Schedules.
16.3 The price to be quoted in the Bid Submission Sheet shall be the total price of the Bid excluding any discounts offered.
16.4 The Bidder shall quote any unconditional discounts and the methodology for their application in the Bid Submission Sheet.
16.5 The terms EXW, CIF, CIP and other similar terms shall be governed by the rules prescribed in the current edition of Incoterms, published by The International Chamber of Commerce as specified in the BDS.
16.6 Unless otherwise stated in the BDS, Prices shall be quoted inclusive of all applicable taxes and levies, insurance, transportation, handling costs and any other associated cost to fulfill the contractual obligations, as specified in the Price Schedule forms for Goods and related services included in Section IV Bidding Forms. However to avail margin of preference, prices shall be quoted as specified in the Price Schedule for Goods Manufactured in Bhutan in section IV Bidding Forms.. The disaggregation of price components shall be solely for the purpose of facilitating the comparison of Bids by the Purchaser. This shall not in any way limit the Purchaser's right to contract on any of the terms offered. In quoting prices the Bidder shall be free to use transportation through carriers registered in any eligible country, in accordance with Section V, Eligible Countries. Similarly, the Bidder may obtain insurance services from any eligible country in accordance with Section V, Eligible Countries. Prices shall be entered in the following manner:
(a) For goods manufactured in Bhutan:
(i) the price of the Goods quoted EXW (ex works, ex factory, ex warehouse, ex showroom, or off-the-shelf, as applicable), including all Customs duties and sales and other taxes already paid or payable on the components and raw material used in the manufacture or assembly of the Goods;
(ii) any Bhutan sales and other taxes which will be payable on the Goods if the contract is awarded to the Bidder; and



<p>(iii) the price for inland transportation, insurance and other local services required to deliver the Goods to their final destination (Project Site) specified in the BDS.</p> <p>(b) for Related Services, other than inland transportation and other services required to convey the Goods to their final destination, whenever such Related Services are specified in the Schedule of Supply:</p> <p>(i) the price of each item comprising the Related Services (inclusive of any applicable taxes).</p> <p>16.7 If so indicated in ITB Sub-Clause 1.1, Bids are being invited for individual items, lots or packages. Unless otherwise indicated in the BDS, prices quoted shall correspond to one hundred percent (100%) of the items specified for each lot and to one hundred percent (100%) of the quantities for each item of a lot. Bidders wishing to offer any price reduction (discount) for the award of more than one Contract shall specify in their Bid the price reductions applicable to each package, or alternatively, to individual Contracts within the package. Price reductions or discounts shall be submitted in accordance with ITB Sub-Clause 16.4, provided the Bids for all lots are submitted and opened at the same time.</p>
<p>17. Price Variation</p> <p>17.1 Prices quoted by the Bidder shall be fixed during the Bidder's performance of the Contract and not subject to variation on any account, unless otherwise specified in the BDS. A Bid submitted with an adjustable price quotation shall be treated as non-responsive and shall be rejected pursuant to ITB Clause 33 unless adjustable price quotations are permitted by the BDS. If, in accordance with the BDS, prices quoted by the Bidder shall be subject to adjustment during the performance of the Contract, a Bid submitted with a fixed price quotation shall not be rejected, but the price adjustment shall be treated as zero.</p>
<p>18. Currencies of Bid</p> <p>18.1 The unit rates and prices shall be quoted by the Bidder entirely in Ngultrum (Nu). Foreign currency requirements shall be indicated and shall be payable at the option of the Bidder in up to three foreign currencies.</p> <p>18.2 The rates of exchange to be used in arriving at the local currency equivalent shall be the selling rates for similar transactions established by RMA on the day of bid opening. These exchange rates shall apply for all payments so that no exchange risk shall be borne by the Bidder.</p> <p>18.3 Bids shall be evaluated as quoted in Ngultrum (NU) in accordance with ITB Sub-Clause 18.1, unless a Bidder has used different exchange rates than those prescribed in ITB Sub-Clause 18.2, in which case the Bid shall be first converted into the amounts payable in different currencies using the rates quoted in the Bid and then reconverted to Ngultrum (NU) using the exchange rates prescribed in ITB Sub-Clause 18.2.</p> <p>18.4 Bidders shall indicate details of their expected foreign currency requirements in the Bid.</p> <p>18.5 Bidders may be required by the Employer to clarify their foreign currency requirements and to substantiate that the amounts included in the rates and prices if required in the BDS, are</p>



<p>reasonable and responsive to ITB Sub-Clause 18.1.</p> <p>18.6 In case of International Procurement from countries other than India, the procuring agency may invite bids in convertible currencies. The bids shall however, be evaluated in accordance with Sub-Clause 18.3 above, but the payment shall be made in the currency of bid.</p>
<p>19. Documents Establishing the Eligibility of the Bidder</p> <p>19.1 To establish their eligibility in accordance with ITB Clause 3, Bidders shall complete the Bid Submission Sheet included in Section IV, Bidding Forms.</p>
<p>20. Documents Establishing the Eligibility of the Goods and Related Services</p> <p>20.1 To establish the eligibility of the Goods and Related Services in accordance with ITB Clause 5, Bidders shall complete the country of origin declarations in the Price Schedule Forms included in Section IV, Bidding Forms.</p>
<p>21. Documents Establishing the Conformity of the Goods and Related Services</p> <p>21.1 To establish the conformity of the Goods and Related Services to the Bidding Documents, the Bidder shall furnish as part of its Bid documentary evidence that the Goods conform to the technical specifications and standards specified in Section VI, Schedule of Supply.</p> <p>21.2 The documentary evidence may be in the form of literature, drawings or data, and shall consist of a detailed item by item description of the essential technical and performance characteristics of the Goods and Related Services, demonstrating substantial responsiveness of the Goods and Related Services to the technical specifications and, if applicable, a statement of deviations and exceptions to the provisions of the Schedule of Supply.</p> <p>21.3 The Bidder shall also furnish a list giving full particulars, including available sources and current prices of spare parts, special tools, etc., necessary for the proper and continuing functioning of the Goods during the period specified in the BDS following commencement of the use of the Goods by the Purchaser.</p> <p>21.4 Standards for workmanship, process, material and equipment, as well as references to brand names or catalogue numbers specified by the Purchaser in the Schedule of Supply, are intended to be descriptive only and not restrictive. The Bidder may offer other standards of quality, brand names and/or catalogue numbers, provided that it demonstrates to the Purchaser's satisfaction that the substitutions ensure equivalence or are superior to those specified in the Schedule of Supply.</p>
<p>22. Documents Establishing the Qualifications of the Bidder</p> <p>22.1 The documentary evidence of the Bidder's qualifications to perform the contract if its Bid is accepted shall establish to the Purchaser's satisfaction:</p> <p>(a) that, if required by the BDS, a Bidder that does not manufacture or produce the Goods it offers to supply shall submit the Manufacturer's Authorization using the form included in Section IV, Bidding Forms to demonstrate that it has been duly authorized by the manufacturer or producer of the Goods to supply these Goods in Bhutan;</p> <p>(b) that, if required in the BDS, in the case of a Bidder not doing business within Bhutan, the Bidder is or will be (if awarded the Contract) represented by an agent in Bhutan equipped and able to carry out the Supplier's maintenance, repair and spare parts-</p>



stocking obligations prescribed in the Conditions of Contract and/or Technical Specifications;

- (c) that Bids submitted by a Joint Venture, Consortium or Association (JV/C/A) of two or more firms as partners comply with the following requirements:
- (i) the Bid is signed so as to be legally binding on all partners;
 - (ii) all partners shall be jointly and severally liable for the execution of the Contract in accordance with the Contract terms;
 - (iii) one of the partners is nominated as being in charge, authorized to incur liabilities, and to receive instructions for and on behalf of any and all partners of the JV/C/A;
 - (iv) the execution of the entire Contract, including payment, shall be done exclusively with the partner in charge; and
 - (v) a copy of the JV/C/A Agreement entered into by the partners is submitted with the Bid; or a Letter of Intent to execute a JV/C/A Agreement in the event of a successful Bid is signed by all partners and submitted with the Bid, together with a copy of the proposed Agreement.
- (d) that the Bidder meets each of the qualification criteria specified in Section III, Evaluation and Qualification Criteria.

23. Period of Validity of Bids

- 23.1 Bids shall remain valid for the period specified in the BDS from the Bid submission deadline prescribed by the Purchaser. A Bid valid for a shorter period shall be rejected by the Purchaser as non-responsive.
- 23.2 In exceptional circumstances, prior to expiry of the Bid validity period, the Purchaser may request Bidders to extend the period of validity of their Bids. The request and the responses shall be made in writing. The Bid Security shall also be extended for a corresponding period. A Bidder may refuse the request to extend the validity of its Bid without forfeiting its Bid Security. A Bidder granting the request shall not be required or permitted to modify its Bid, except as provided in ITB Sub-Clause 23.3
- 23.3 In the case of fixed price contracts, if the award is delayed by a period exceeding sixty (60) days beyond the expiry of the initial Bid validity, the Contract price shall be adjusted as specified in the request for extension. Bid evaluation shall be based on the Bid Price without taking into consideration the above correction.

24. Bid Security

- 24.1 The Bidder shall furnish, as part of its Bid, a Bid Security in original form, denominated in Ngultrum or a freely convertible currency and in the amount specified in the BDS.
- 24.2 The Bid Security shall:
- (a) at the Bidder's option, be in any of the following forms:
 - (i) an Unconditional Bank Guarantee; or



- (ii) a Banker's Certified Cheque/Cash Warrant; or
 - (iii) a Demand Draft;
- (b) be issued by a reputable financial institution acceptable to the Purchaser selected by the Bidder and located in any eligible country. If the institution issuing the Bid Security is located outside Bhutan it shall have a correspondent financial institution located in Bhutan to make the Bid Security enforceable.
 - (c) in the case of a bank guarantee, be substantially in accordance with the form of Bid Security included in Section IV, Bidding Forms, or other form approved by the Purchaser prior to Bid submission;
 - (d) be promptly payable upon written demand by the Purchaser in case any of the conditions listed in ITB Sub-Clause 24.6 are invoked;
 - (e) be submitted in its original form; copies shall not be accepted;
 - (f) remain valid for a period of thirty (30) days beyond the end of the validity period of the Bid, as extended, if applicable, in accordance with ITB Sub-Clause 23.2.
- 24.3 Any Bid not accompanied by a responsive Bid Security shall be rejected by the Purchaser as non-responsive.
- 24.4 The Bid Securities of unsuccessful Bidders shall be returned as promptly as possible upon the successful Bidder furnishing the Performance Security pursuant to ITB Clause 47.
- 24.5 The Bid Security of the successful Bidder shall be returned as promptly as possible after the successful Bidder has signed the Contract and furnished the required Performance Security.
- 24.6 The Bid Security shall be forfeited:
- (a) if a Bidder withdraws its Bid during the period of Bid validity specified by the Bidder on the Bid Submission Sheet, except as provided in ITB Sub-Clause 23.2; or
 - (b) if the successful Bidder fails to:
 - (i) sign the Contract in accordance with ITB Clause 46;
 - (ii) furnish a Performance Security in accordance with ITB Clause 47; or
 - (iii) accept the correction of its Bid Price pursuant to ITB Sub-Clause 34.4
- 24.7 The Bid Security of a JV/C/A must be in the name of the JV/C/A that submits the Bid. If the JV/C/A has not been legally constituted at the time of bidding the Bid Security shall be in the names of all future partners as named in the letter of intent.

25. Format and Signing of Bid

- 25.1 The Bidder shall prepare ONE Original of the documents comprising the Bid as described in ITB Clause 12 and clearly mark it "ORIGINAL." In addition, the Bidder shall submit copies of the Bid, in the number specified in the BDS, and clearly mark them "COPY." In the event of any discrepancy between the original and the copies, the original shall prevail.



25.2 The original and all copies of the Bid shall be typed or written in indelible ink and shall be signed by a person duly authorized to sign on behalf of the Bidder.

25.3 Any interlineations, erasures or overwriting shall be valid only if they are signed or initialed by the person signing the Bid.

D. Submission and Opening of Bids

26. Submission, Sealing and Marking of Bids

26.1 Bids shall be delivered by hand, courier or registered post. The Bidder shall seal the original of the Bid and the number of copies stipulated in the BDS, including alternative Bids if permitted in accordance with ITB Clause 15, in separate inner envelopes contained within one outer envelope. All envelopes shall be sealed with adhesive or other sealant to prevent reopening.

26.2 The inner envelopes shall:

- (a) be signed across their seals by the person authorized to sign the Bid on behalf of the Bidder; and
- (b) be marked "ORIGINAL", "ALTERNATIVE" (if any) and "COPIES";

26.3 The outer envelope shall:

- (a) be marked "Confidential";
- (b) be addressed to the Purchaser at the address⁷ provided in the BDS;
- (c) bear the name and identification number of the Contract as defined in the BDS; and
- (d) provide a warning not to open before the specified time and date for Bid Opening as defined in the BDS.

26.4 In addition to the identification required in ITB Sub-Clause 26.2, the inner envelopes shall indicate the name and address of the Bidder, to enable the Bid to be returned unopened in case it is declared late pursuant to ITB Clause 28.

26.5 If the outer envelope is not sealed and marked as above, the Purchaser shall assume no responsibility for the misplacement or premature opening of the Bid.

26.6 In the Two-Stage Process, Bidders shall be advised to submit only the technical proposal in the first stage. In the second stage, Bidders shall be requested to submit both their technical proposals as modified and agreed with the Purchaser and the financial proposals based on the modified technical proposal simultaneously in two separate sealed envelopes.

26.7 When so specified in the BDS Bidders shall have the option of submitting their Bids electronically. Bidders submitting Bids electronically shall follow the procedures specified in the BDS.

27. Deadline for Submission of Bids

⁷ The receiving address shall be an office that is staffed during normal working hours by personnel authorized to certify time and date of receipt and assure safe-keeping until Bid opening. A post office address is not to be used. The address must be the same as the receiving address described in the Invitation for Bids.



<p>27.1 Bids shall be delivered by hand, courier or registered post to the Purchaser at the address and no later than the date and time indicated in the BDS.</p> <p>27.2 The Purchaser may, at its discretion, extend the deadline for the submission of Bids by amending the Bidding Documents in accordance with ITB Clause 9, in which case all rights and obligations of the Purchaser and Bidders previously subject to the deadline shall thereafter be subject to the deadline as extended.</p>
<p>28. Late Bids</p> <p>28.1 The Purchaser shall not consider any Bid that arrives after the deadline for submission of Bids. Any Bid received by the Purchaser after the deadline for submission of Bids shall be declared late, rejected, and returned unopened to the Bidder.</p>
<p>29. Withdrawal, Substitution and Modification of Bids</p> <p>29.1 A Bidder may withdraw, substitute or modify its Bid after it has been submitted by sending a written notice in accordance with ITB Clause 26, duly signed by an authorized representative, and shall include a copy of the authorization (the power of attorney) in accordance with ITB Sub-Clause 25.2, (except that withdrawal notices do not require copies). The corresponding substitution or modification of the Bid must accompany the respective written notice. All notices must be:</p> <ul style="list-style-type: none"> (a) submitted in accordance with ITB Clauses 25 and 26 (except that withdrawal notices do not require copies) and, in addition, the respective envelopes shall be clearly marked “WITHDRAWAL”, “SUBSTITUTION” or “MODIFICATION;” and (b) received by the Purchaser prior to the deadline prescribed for submission of Bids, in accordance with ITB Clause 27. <p>29.2 Bids requested to be withdrawn in accordance with ITB Sub-Clause 29.1 shall be returned unopened to the Bidders.</p> <p>29.3 No Bid may be withdrawn, substituted or modified in the interval between the deadline for submission of Bids and the expiry of the period of Bid validity specified by the Bidder on the Bid Submission Sheet or any extension thereof.</p> <p>29.4 Withdrawal of a bid between the deadline for submission of bids and expiration of the period of bid validity specified in the BDS or as extended pursuant to Clause 23.1, may result in the forfeiture of the Bid Security pursuant to Clause 24.6. If the lowest or the lowest evaluated bidder withdraws his bid between the periods specified in this clause, the bid security of the bidder shall be forfeited and in addition, the bidder shall pay to the employer the positive difference of sum, if any, with the next lowest bidder within fourteen (14) days of his withdrawal. If the bidder fails to pay the difference within the said date, the bidder shall be debarred by a competent authority as per law. In the case of framework contracts, the bid security shall be forfeited and the supply of the particular item will be re-tendered.</p>
<p>30. Bid Opening</p> <p>30.1 The Purchaser shall conduct the Bid Opening in public, in the presence of Bidders’ designated representatives who choose to attend, and at the address, date and time specified in the BDS. Any specific electronic Bid Opening procedures required if electronic bidding is</p>



permitted in accordance with ITB Sub-Clause 26.7 shall be as specified in the BDS.

- 30.2 Bidders, their representatives and other attendees at the Bid Opening shall not be permitted to approach any members of the Bid Opening Committee or any CST officials.
- 30.3 First, envelopes marked “WITHDRAWAL” shall be opened and read out and the envelope with the corresponding Bid shall not be opened, but shall be returned to the Bidder. No Bid withdrawal shall be permitted unless the corresponding withdrawal notice contains a valid authorization to request the withdrawal and is read out at Bid Opening. Next, envelopes marked “SUBSTITUTION” shall be opened and read out and exchanged with the corresponding Bid being substituted. The substituted Bid shall not be opened, but shall be returned to the Bidder. No Bid substitution shall be permitted unless the corresponding substitution notice contains a valid authorization to request the substitution and is read out at Bid Opening. Envelopes marked “MODIFICATION” shall be opened and read out with the corresponding Bid. No Bid modification shall be permitted unless the corresponding modification notice contains a valid authorization to request the modification and is read out at Bid Opening. Only envelopes that are opened and read out at Bid Opening shall be considered further.
- 30.4 All other envelopes shall be opened one at a time. The Bidders’ names, the Bid prices, the total amount of each Bid and of any alternative Bid (if alternatives have been requested or permitted), any discounts, Bid withdrawals, substitutions or modifications, the presence or absence of Bid Security, responses to any Bidding Documents addenda, and such other details as the Purchaser may consider appropriate shall be announced by the Purchaser at the Bid Opening. This information also shall be written on a notice board for the public to copy. Any Bid price, discount or alternative Bid price not announced and recorded shall not be taken into account in Bid evaluation. No Bid shall be rejected at Bid Opening except for late Bids pursuant to ITB Clause 28, Non-signing of Bid Submission Sheet and Price Schedules, and Bid Security not in accordance with ITB 24. Substitution Bids and modifications submitted pursuant to ITB Clause 29 that are not opened and read out at Bid Opening shall not be considered for further evaluation regardless of the circumstances. Late, withdrawn and substituted Bids shall be returned unopened to Bidders.
- 30.5 The Purchaser shall prepare a record of the Bid Opening, which shall include the information disclosed to those present in accordance with ITB Sub-Clause 30.4. The minutes shall include, as a minimum:
- (a) the Contract title and reference number;
 - (b) the Bid number;
 - (c) the Bid deadline date and time;
 - (d) the date, time and place of Bid Opening;
 - (e) Bid prices, per lot if applicable, offered by the Bidders, including any discounts and alternative offers;
 - (f) the presence or absence of Bid Security and, if present, its amount;
 - (g) the name and nationality of each Bidder, and whether there is a withdrawal, substitution or modification;



<p>(h) the names of attendees at the Bid Opening, and of the Bidders they represent (if any);</p> <p>(i) details of any complaints or other comments made by attendees/representatives attending the Bid Opening, including the names and signatures of the attendees/representatives making the complaint(s) and/or comment(s); and</p> <p>(j) the names, designations and signatures of the members of the Bid Opening Committee.</p> <p>The Bidders' representatives and attendees who are present shall be requested to sign the record. The omission of a Bidder's or other attendee's signature on the record shall not invalidate the contents and effect of the record. A copy of the record shall be distributed to all Bidders.</p>
<p>E. Evaluation and Comparison of Bids</p>
<p>31. Confidentiality</p> <p>31.1 Information relating to the examination, evaluation, comparison and postqualification of Bids, and recommendation of Contract Award, shall not be disclosed to Bidders or any other persons not officially concerned with such process until publication of the Contract Award.</p> <p>31.2 Any effort by a Bidder to influence the Purchaser in the examination, evaluation, comparison and postqualification of the Bids or Contract Award decisions may result in the rejection of its Bid.</p> <p>31.3 Notwithstanding ITB Sub-Clause 31.2, from the time of Bid Opening to the time of Contract Award, if any Bidder wishes to contact the Purchaser on any matter related to the bidding process, it should do so in writing.</p>
<p>32. Clarification of Bids</p> <p>32.1 To assist in the examination, evaluation, comparison and postqualification of the Bids, the Purchaser may, at its discretion, ask any Bidder for a clarification of its Bid. Any clarification submitted by a Bidder that is not in response to a request by the Purchaser shall not be considered. The Purchaser's request for clarification and the response shall be in writing. No change in the prices or substance of the Bid shall be sought, offered or permitted, except to confirm the correction of arithmetic errors discovered by the Purchaser in the evaluation of the Bids, in accordance with ITB Clause 34.</p>
<p>33. Responsiveness of Bids</p> <p>33.1 The Purchaser's determination of a Bid's responsiveness shall be based on the contents of the Bid itself, and is to determine which of the Bids received are responsive and thereafter to compare the responsive Bids against each other to select the lowest evaluated Bid.</p> <p>33.2 A substantially responsive Bid is one that conforms to all the terms, conditions and specifications of the Bidding Documents without material deviation, reservation or omission. A material deviation, reservation or omission is one that:</p> <p>(a) affects in any substantial way the scope, quality or performance of the Goods or Related Services required; or</p> <p>(b) limits in any substantial way inconsistent with the Bidding Documents, the</p>



<p>Purchaser's rights or the Bidder's obligations under the Contract; or</p> <p>(c) if rectified would affect unfairly the competitive position of other Bidders presenting responsive Bids</p> <p>33.3 If a Bid is not substantially responsive to the Bidding Documents it shall be rejected by the Purchaser and may not subsequently be made responsive by the Bidder by correction of the material deviation, reservation or omission.</p>
<p>34. Nonconformities, Errors and Omissions</p> <p>34.1 Provided that a Bid is substantially responsive, the Purchaser may waive any non-conformities or omissions in the Bid that do not constitute a material deviation.</p> <p>34.2 Provided that a Bid is substantially responsive, the Purchaser may request that the Bidder submit the necessary information or documentation, within a reasonable period of time, to rectify nonmaterial nonconformities or omissions in the Bid related to documentation requirements. Such omission shall not be related to any aspect of the price of the Bid. Failure of the Bidder to comply with the request may result in the rejection of its Bid.</p> <p>34.3 Provided that the Bid is substantially responsive, the Purchaser shall correct arithmetical errors on the following basis:</p> <p>(a) if there is a discrepancy between the unit price and the line item total that is obtained by multiplying the unit price by the quantity, the unit price shall prevail and the line item total shall be corrected, unless in the opinion of the Purchaser there is an obvious misplacement of the decimal point in the unit price, in which case the line item total as quoted shall govern and the unit price shall be corrected;</p> <p>(b) if there is an error in a total corresponding to the addition or subtraction of subtotals, the subtotals shall prevail and the total shall be corrected; and</p> <p>(c) if there is a discrepancy between words and figures, the amount in words shall prevail, unless the amount expressed in words is related to an arithmetic error, in which case the amount in figures shall prevail subject to ITB Sub-Clauses 34.3 (a) and (b) above.</p> <p>34.4 If the Bidder that submitted the lowest evaluated Bid does not accept the correction of errors, its Bid shall be disqualified and its Bid Security shall be forfeited.</p>
<p>35. Preliminary Examination of Bids</p> <p>35.1 The Purchaser shall examine the Bids to confirm that all documents and technical documentation requested in ITB Clause 12 have been provided, and to determine the completeness of each document submitted.</p> <p>35.2 The Purchaser shall confirm that the following documents and information have been provided in the Bid. If any of these documents or information is missing, the offer shall be rejected.</p> <p>(a) Bid Submission Sheet, in accordance with ITB Sub-Clause 12.1 (a);</p> <p>(b) Price Schedules, in accordance with ITB Sub-Clause 12.1 (a);</p> <p>(c) Bid Security, in accordance with ITB Clause 24.</p>



36. Examination of Terms and Conditions; Technical Evaluation

- 36.1 The Purchaser shall examine the Bid to confirm that all terms and conditions specified in the GCC and the SCC have been accepted by the Bidder without any material deviation or reservation.
- 36.2 The Purchaser shall evaluate the technical aspects of the Bid submitted in accordance with ITB Clause 21, to confirm that all requirements specified in Section VI, Schedule of Supply of the Bidding Documents have been met without any material deviation or reservation.
- 36.3 If, after the examination of the terms and conditions and the technical evaluation, the Purchaser determines that the Bid is not substantially responsive in accordance with ITB Clause 33, it shall reject the Bid.

37. Conversion to Single Currency

- 37.1 For evaluation and comparison purposes, the Purchaser shall convert all Bid prices expressed in amounts in various currencies into a single currency and using the exchange rates specified in the BDS.

38. Margin of Preference

- 38.1 A margin of preference may apply to domestic goods manufactured in Bhutan as provided for in the BDS. To avail a margin of preference, the bidder shall provide a value addition certificate from the Ministry of Economic Affairs.

39. Evaluation of Bids

- 39.1 The Purchaser shall evaluate each Bid that has been determined, up to this stage of the evaluation, to be substantially responsive.
- 39.2 To evaluate a Bid, the Purchaser shall only use all the factors, methodologies and criteria defined in this ITB Clause 39. No other criteria or methodology shall be permitted.
- 39.3 To evaluate a Bid, the Purchaser shall consider the following:
- (a) evaluation shall be done for Items or Lots, as specified in the BDS;
 - (b) the Bid Price, as quoted in accordance with ITB Clause 16;
 - (c) price adjustment for correction of arithmetic errors in accordance with ITB Clause 34.3;
 - (d) price adjustment due to discounts offered in accordance with ITB Clause 16.4;
 - (e) adjustments due to the application of the evaluation criteria specified in the BDS from amongst those set out in Section III, Evaluation and Qualification Criteria; and
 - (f) adjustments due to the application of a margin of preference, in accordance with ITB Clause 38, if applicable.
- 39.4 The Purchaser's evaluation of a Bid shall exclude and not take into account:
- (a) in the case of Goods manufactured in Bhutan, sales and other similar taxes which will be



payable on the Goods if the Contract is awarded to the Bidder;

- (b) in the case of Goods manufactured outside Bhutan, already imported or to be imported, Customs duties and other import taxes levied on the imported Goods, sales and other similar taxes which will be payable on the Goods if the Contract is awarded to the Bidder; and
- (c) any allowance for price adjustment during the period of execution of the Contract, if provided in the Bid.

39.5 The Purchaser's evaluation of a Bid may require the consideration of other factors in addition to the Bid Price quoted in accordance with ITB Clause 16. These factors may be related to the characteristics, performance, and terms and conditions of purchase of the Goods and Related Services. The effect of the factors selected, if any, shall be expressed in monetary terms to facilitate comparison of Bids, unless otherwise specified in Section III, Evaluation and Qualification Criteria. The factors, criteria and the methodology of application shall be as specified in ITB Sub-Clause 39.3 (e).

39.6 If so specified in the BDS, these Bidding Documents shall allow Bidders to quote separate prices for one or more lots, and shall allow the Purchaser to award one or multiple lots to more than one Bidder. The methodology of evaluation to determine the lowest evaluated lot combinations is specified in Section III, Evaluation and Qualification Criteria.

40. Comparison of Bids

40.1 The Purchaser shall compare all substantially responsive Bids to determine the lowest evaluated Bid, in accordance with ITB Sub-Clause 39.

40.2 If the Bid price of the lowest evaluated Bid appears abnormally low and/or seriously unbalanced, the Purchaser may require the Bidder to produce written explanations of, justifications and detailed price analyses for any or all items offered. Such explanations may include, but are not limited to, details of the method by which the Goods and Related Services are to be provided, the technical solutions chosen, exceptionally favorable conditions available to the Bidder for the execution of the Contract, and the originality of the Goods proposed by the Bidder. After objective evaluation of the explanations, justifications and price analyses, if the Purchaser decides to accept the Bid with an abnormally low and/or seriously unbalanced price, the Purchaser shall require that the amount of the Performance Security stipulated in ITB Clause 47 be increased at the expense of the Bidder to a level sufficient to protect the Purchaser against financial loss in the event of default of the successful Bidder under the Contract.

41. Postqualification of the Bidder

41.1 The Purchaser shall determine to its satisfaction whether the Bidder that is selected as having submitted the lowest evaluated and substantially responsive Bid is qualified to perform the Contract satisfactorily.

41.2 The determination shall be based upon an examination of the documentary evidence of the Bidder's qualifications submitted by the Bidder, pursuant to ITB Clause 22.



41.3	An affirmative determination shall be a prerequisite for award of the Contract to the Bidder. A negative determination shall result in disqualification of the Bid, in which event the Purchaser shall proceed to the next lowest evaluated Bid to make a similar determination of that Bidder's capabilities to perform satisfactorily.
42. Purchaser's Right to Accept Any Bid, and to Reject Any or All Bids	
42.1	The Purchaser reserves the right to accept or reject any Bid, and to annul the bidding process and reject all Bids at any time prior to Contract award, without thereby incurring any liability to Bidders.
F. Award of Contract	
43. Award Criteria	
43.1	The Purchaser shall award the Contract to the Bidder whose offer has been determined to be the lowest evaluated Bid and is substantially responsive to the Bidding Documents, provided further that the Bidder is determined to be qualified to perform the Contract satisfactorily.
44. Purchaser's Right to Vary Quantities at Time of Award	
44.1	At the time the Contract is awarded, the Purchaser reserves the right to increase or decrease the quantity of Goods and Related Services originally specified in Section VI, Schedule of Supply, provided this does not exceed the percentages indicated in the BDS, and without any change in the unit prices or other terms and conditions of the Bid and the Bidding Documents.
45. Notification of Award	
45.1	Prior to expiry of the period of Bid validity, the Purchaser shall notify the successful Bidder, in writing, that its Bid has been accepted.
45.2	Until a formal Contract is prepared and executed, the notification of award shall constitute a binding Contract.
45.3	Upon the successful Bidder furnishing the signed Contract Form and the Performance Security pursuant to ITB Clause 47 the Purchaser: <ul style="list-style-type: none"> (a) shall promptly notify each unsuccessful Bidder and discharge its Bid Security, pursuant to ITB Sub-Clause 24.4; and (b) publish a notification of award on the Purchaser's website.
45.4	The notifications to all unsuccessful Bidders and the notification posted on the Purchaser's website shall include the following information: <ul style="list-style-type: none"> (a) the Bid and lot numbers; (b) name of the winning Bidder, and the price it offered, as well as the duration and summary scope of the Contract awarded; and



(c) the date of the award decision.

45.5 After publication of the award, unsuccessful Bidders may request in writing to the Purchaser for a debriefing seeking explanations of the grounds on which their Bids were not selected. The Purchaser shall promptly respond in writing to any unsuccessful Bidder who, after publication of contract award, requests a debriefing.

46 Signing of Contract

46.1 At the same time as notifying the successful Bidder in writing that its Bid has been accepted the Purchaser shall send the successful Bidder the Contract Agreement and the Special Conditions of Contract.

46.2 Within fifteen (15) days of receipt of the Contract Agreement the successful Bidder shall sign, date and return it to the Purchaser.

46.3 Notwithstanding ITB Sub-Clause 46.2 above, in case signing of the Contract Agreement is prevented by any export restrictions attributable to the Purchaser, to Bhutan, or to the use of the products/Goods, systems or services to be supplied, where such export restrictions arise from trade regulations from a country supplying those products/Goods, systems or services, the Bidder shall not be bound by its Bid, always provided, however, that the Bidder can demonstrate to the satisfaction of the Purchaser that signing of the Contract Agreement has not been prevented by any lack of diligence on the part of the Bidder in completing any formalities, including applying for permits, authorizations and/or licenses necessary for the export of the products/Goods, systems or services under the terms of the Contract.

47 Performance Security

47.1 Within fifteen (15) working days of the receipt of notification of award from the Purchaser, the Bidder shall submit the Performance Security in accordance with the GCC, using for that purpose any of the following security forms:

- (a) unconditional bank guarantee in the form provided for in Section IX, Contract Forms, or another form acceptable to the Purchaser, or
- (b) banker's certified cheque/cash warrant, or
- (c) demand draft.

47.2 If the Performance Security is provided by the successful Bidder in the form of a demand bank guarantee it shall be issued, at the Bidder's option, by a bank located in Bhutan or by a foreign bank acceptable to the Purchaser through a correspondent bank located in Bhutan.

47.3 Failure by the successful Bidder to submit the above-mentioned Performance Security or to sign the Contract shall constitute sufficient grounds for the annulment of the award and forfeiture of the Bid Security. In that event the Purchaser may award the Contract to the next lowest evaluated Bidder whose offer is substantially responsive and is determined by the Purchaser to be qualified to perform the Contract satisfactorily. Such a failure shall be considered as "withdrawal" and all relevant clauses shall apply.



Section II. Bid Data Sheet

A. Introduction	
ITB 1.1	The Purchaser is: <i>College of Science and Technology</i>
ITB 1.1	The name, identification number and number of lots within this procurement are: PKG-06 Supply of Library Furniture
B. Bidding Documents	
ITB 8.2	For clarification of Bid purposes only, the Purchaser's address is: Attention: <i>ADM Officer</i> Address: <i>College of Science and Technology, Rinchending, Post Box No.450, Phuentsholing, Bhutan</i> Facsimile number: 17160538 Electronic mail address: schoden.cst@rub.edu.bt
C. Preparation of Bids	
ITB 11.1	The language of the Bid is: <i>English</i>
ITB 12.1 (k)	The Bidder shall submit with its Bid the following additional documents: <i>Trade Licence, Tax Clearance Certificate, Dealership Certificate from the intended company, Original catalogues of items, discount statement if any etc. Acknowledgement letter from the past agencies if any.</i>
ITB 12.1 (j)	The bidders shall submit a signed Integrity Pact: <i>Yes</i>
ITB 15.1	Alternative Bids <i>shall not be</i> permitted.
ITB 16.5	The Incoterms edition is: <i>2015 version DDP</i>
ITB 16.6 (a) (iii), (b) (ii) and (c) (v)	The final destination (Project Site) is: <i>College of Science and Technology, Rinchending, Phuentsholing, Bhutan</i>
ITB 17.1	The prices quoted by the Bidder <i>shall not</i> be adjustable. If prices shall be adjustable, the methodology is specified in Section III, Evaluation and Qualification Criteria.
ITB 18.1	The Bidder <i>is</i> required to quote in Ngultrum (BTN) the portion of the Bid Price that corresponds to expenditures incurred in Ngultrum (BTN) in Bhutan.
ITB 21.3	The period of time for which the Goods are expected to be functioning (for the purpose of spare parts, special tools, etc) is <i>5 years</i>



ITB 23.1	The Bid validity period shall be 60 days.
ITB 24.1	The amount and currency of the Bid Security is 2% of the total bid price in the form of: <i>a) Unconditional bank guarantee issued by the financial institute in Bhutan; or</i> <i>b) Demand draft in favour of Director, College of Science & Technology, RUB, Phuentsholing.</i>
D. Submission and Opening of Bids	
ITB 25.1 and 26.1	In addition to the original of the Bid, the number of copies is: ONE
ITB 26.3 (d)	The name and identification number of the Contract is PKG-06 Supply of Library Furniture
ITB 26.3 (e)	The time and date for Bid Opening is 2:00PM Bhutan time 17 July, 2019
ITB 26.7	Bidders shall not have the option of submitting their Bids electronically.
ITB 27.1	For Bid submission purposes, the Purchaser's address is: Attention: President Address: College of Science and Technology, Rinchending, Post Box No.450, Bhutan. The deadline for the submission of Bids is: Date: on 17 July, 2019 Time: 12:00 pm Bhutan time.
ITB 30.1	The Bid Opening shall take place at: Address: Quality Hall Date: on 17 July, 2019 Time: 2:00pm Bhutan time
E. Evaluation and Comparison of Bids	
ITB 37.1	Bid prices expressed in different currencies shall not be accepted
ITB 38.1	A margin of five percent (5%) Domestic Preference <i>shall</i> apply.
ITB 39.3 (a)	Evaluation will be done for <i>Items Wise</i> <i>Bids will be evaluated for each item and the Contract will comprise the item(s) awarded to the successful Bidder.</i>
ITB 39.3 (e)	The adjustments shall be determined using the following criteria from amongst those set out in Section III, Evaluation and Qualification Criteria: <i>[refer to</i>



	<p><i>Schedule III, Evaluation and Qualification Criteria; insert complementary details if necessary]</i></p> <p>(a) Deviation in Delivery schedule: <i>Yes. 0.1% for every day of delay.</i></p> <p>(b) Deviation in payment schedule: <i>No</i></p> <p>(c) The cost of major replacement components, mandatory spare parts, and service: <i>[insert Yes or No. If Yes, insert the methodology and criteria]</i></p> <p>(d) The availability in Bhutan of spare parts and after-sales services for the equipment offered in the Bid <i>No.</i></p> <p>(e) The projected operating and maintenance costs during the life of the equipment <i>No</i></p> <p>(f) The performance and productivity of the equipment offered: <i>[Insert Yes or No. If Yes, insert the methodology and criteria]</i></p> <p>(g) <i>[Insert any other specific criteria]</i></p>
ITB 39.6	Bidders <i>shall not</i> be allowed to quote separate prices for one or more Item/lots.
F. Award of Contract	
ITB 44.1	<p>The maximum percentage by which quantities may be increased is <u>50%</u></p> <p>The maximum percentage by which quantities may be decreased is <u>50%</u></p>



Section III. Evaluation and Qualification Criteria

1. Margin of Preference (ITB Clause 38)
2. Evaluation Criteria (ITB Sub-Clause 39.3 (e))
3. Multiple Contracts (ITB Sub-Clause 39.6)
4. Postqualification Requirements (ITB Sub-Clause 41.2)



1. Domestic Preference (ITB 38)

- 1.1 If the Bidding Data Sheet (BDS) so specifies, the purchaser may grant a margin of preference to goods manufactured in the Purchaser's country for the purpose of bid comparison, in accordance with the procedure outlined in subsequent paragraphs:
- 1.2 Bids will be classified in one of the three groups, as follows:
- a) Group A: Bids offering goods manufactured in Bhutan, for which (i) labour, raw materials and components form within the country account for more than thirty (30) percent of the EXW price; and (ii) the production facility in which they will be manufactured or assembled has been engaged in manufacturing or assembling such goods at least since the date of bid submission.
 - b) Group B: All other bids offering Goods manufactured in Bhutan
 - c) Group C: Bids offering Goods manufactured outside Bhutan that have been already imported or that will be imported.
- 1.3 The price quoted for goods in bids of Group A and B shall include all duties and taxes paid or payable on the basic materials or components purchased in the domestic market or imported, but shall exclude the sales and similar taxes on the finished product. The price quoted for goods in bids of Group C shall be on CIF or CIP (place of destination), which is exclusive of customs duties and other import taxes already paid or to be paid.
- 1.4 In the first step, all evaluated bids in each group shall be compared to determine the lowest bid in each group. Such lowest evaluated bids shall be compared with each other and if, as a result of this comparison, a bid from Group A or Group B is the lowest, it shall be selected for the award.
- 1.5 If as a result of preceding comparison, the lowest evaluated bid is a bid from Group C, the lowest evaluated bid from Group C shall be further compared with the lowest evaluated bid from Group A after adding to the lowest evaluated price of goods offered in the bid from Group C, for the purpose of this further comparison only, an amount equal to five (5) percent of the CIF or CIP bid price. The lowest evaluated bid determined from this last comparison shall be selected for the award.

2. Evaluation Criteria (ITB 39.3 (e))

The Purchaser's evaluation of a Bid may take into account, in addition to the Bid Price quoted in accordance with ITB Sub-Clause 16.6, one or more of the following factors as specified in ITB Sub-Clause 39.3(e) and in the BDS referring to ITB Sub-Clause 39.3(e), using the following criteria and methodologies.

- (a) Delivery Schedule. *(as per Incoterms specified in the BDS)*

The Goods are required to be delivered within the acceptable time range (after the earliest and before the final date, both dates inclusive) specified in the List of Goods and Delivery Schedule in Section VI. No credit will be given to deliveries before the earliest date, and Bids offering delivery after the final date shall be treated as non responsive. Within this acceptable period, an adjustment, as specified in BDS Sub-Clause ITB 39.3(e), will be added, for evaluation purposes only, to the Bid price of Bids



offering deliveries later than the “Earliest Delivery Date” specified in Section VI , List of Goods and Delivery Schedule.

- (d) Availability in Bhutan of spare parts and after sales services for equipment offered in the Bid.

An adjustment equal to the cost to the Purchaser of establishing the minimum service facilities and parts inventories, as outlined in BDS Sub-Clause ITB 39.3 (e), if quoted separately, shall be added to the Bid Price, for evaluation purposes only.

3. Multiple Contracts (ITB 39.6)

The Purchaser shall award multiple contracts to the Bidder that offers the lowest evaluated combination of Bids (one contract per Bid) and meets the postqualification criteria (this Section III, Sub-Section ITB Sub-Clause 41.2, Postqualification Requirements)

The Purchaser shall:

- (a) evaluate only lots or contracts that include at least the percentages of items per lot and quantity per item as specified in ITB Sub-Clause 16.7.
- (b) take into account:
- (i) the lowest-evaluated Bid for each lot; and
- (ii) the price reduction per lot and the methodology for its application as offered by the Bidder in its Bid.

4. Postqualification Requirements (ITB 41.2)

After determining the lowest-evaluated Bid in accordance with ITB Sub-Clause 40.1, the Purchaser shall carry out the postqualification of the Bidder in accordance with ITB Clause 41, using only the requirements specified. Requirements not included in the text below shall not be used in the evaluation of the Bidder's qualifications.

- (a) Financial Capability

The Bidder shall furnish documentary evidence that it meets the following financial requirement(s): *A tax clearance certificate from the department of Revenue and Customs OR the audited balance sheets for the last three years by a recognized firm OR a certified statement of the previous five years overall turnover and the turnover in respect of supplies or services.*

- (b) Experience and Technical Capacity

The Bidder shall furnish documentary evidence to demonstrate that it meets the following experience requirement(s): *copy of similar work carried out in the previous 3 years if any.*

- (b) The Bidder shall furnish documentary evidence to demonstrate that the Goods it offers meet the following usage requirement(s):



Section IV. Bidding Forms

Table of Forms

Bidder Information Form 34

Joint Venture, Consortium or Association (JV/C/A) Partner Information Form 35

Bid Submission Sheet 36

Bid Security (Bank Guarantee) 39

Manufacturer’s Authorization 40



Bidder Information Form

[The Bidder shall fill in this Form in accordance with the instructions indicated below. No alterations to its format shall be permitted and no substitutions shall be accepted.]

Date: *[insert date (as day, month and year) of Bid submission]*

Bid No.: *[insert number of bidding process]*

Page _____ of _____ pages

1. Bidder's Legal Name _____
2. In the case of a Joint Venture, Consortium or Association (JV/C/A) legal name of each party: _____
3. Bidder's actual or intended Country of Registration <i>[insert actual or intended Country of Registration]</i> : _____
4. Bidder's Year of Registration <i>[insert Bidder's year of registration]</i> : _____
5. Bidder's Legal Address in Country of Registration <i>[insert Bidder's legal address in country of registration]</i> : _____
<p>6. Bidder's Authorized Representative Information</p> <p>Name<i>[insert Authorized Representative's name]</i>: _____</p> <p>Address<i>[insert Authorized Representative's Address]</i>: _____</p> <p>Telephone/Fax numbers<i>[insert Authorized Representative's telephone/fax numbers]</i> _____</p> <p>E-mail Address<i>[insert Authorized Representative's e-mail address]</i>: _____</p>
<p>7. Attached are copies of the following original documents: <i>[check the box(es) of the attached original documents]</i></p> <p><input type="checkbox"/> Articles of Incorporation or Registration of firm named in 1 above, in accordance with ITB Sub-Clause 3.1.</p> <p><input type="checkbox"/> In the case of a JV/C/A, letter of intent to form the JV/C/A, or the JV/C/A agreement, in accordance with ITB Sub-Clause 22.1 (c) (v).</p> <p><input type="checkbox"/> In the case of a government owned entity from Bhutan, documents establishing legal and financial autonomy and compliance with commercial law, in accordance with ITB Sub-Clause 3.3.</p> <p><input type="checkbox"/> Power of attorney authorizing the signatory of the Bid to sign on behalf of the Bidder.</p>



Joint Venture, Consortium or Association (JV/C/A) Partner Information Form

[The Bidder shall fill in this Form in accordance with the instructions indicated below].

Date *[insert date (as day, month and year) _____ of Bid submission]*

Bid No. *[insert number of bidding process] _____*

Page _____ of _____ pages

1. Bidder's Legal Name <i>[insert Bidder's legal name]: _____</i>
2. JV/C/A Party's legal name <i>[insert JV/C/A Party's legal name]: _____</i>
3. JV/C/A Party's Country of Registration <i>[insert JV/C/A Party's country of registration]: _____</i>
4. JV/C/A Party's Year of Registration: <i>[insert JV/C/A Party's year of registration]: _____</i>
5. JV/C/A Party's Legal Address in Country of Registration <i>[insert JV/C/A Party's legal address in country of registration]: _____</i>
6. JV/C/A Party's Authorized Representative Information Name <i>[insert name of JV/C/A Party's authorized representative]: _____</i> Address <i>[insert address of JV/C/A Party's authorized representative]: _____</i> Telephone/Fax numbers <i>[insert telephone/fax numbers of JV/C/A Party's authorized representative]: _____</i> E-mail Address <i>[insert e-mail address of JV/C/A Party's authorized representative]: _____</i>
7. Attached are copies of the following original documents: <i>[check the box(es) of the attached original documents]</i> <input type="checkbox"/> Articles of Incorporation or Registration of firm named in 2 above, in accordance with ITB Sub-Clause 3.1. <input type="checkbox"/> In the case of a government owned entity from Bhutan, documents establishing legal and financial autonomy and compliance with commercial law, in accordance with ITB Sub-Clause 3.3.



Bid Submission Sheet

[The Bidder shall fill in this form in accordance with the instructions indicated. No alterations to its format shall be permitted and no substitutions shall be accepted.]

Date:

Invitation for Bid No:

To *[insert complete name of the Purchaser]*: _____

We, the undersigned, declare that:

(a) We have examined and have no reservations to the Bidding Documents, including Addenda No. *[insert the number and date of issue of each addendum]*:

(b) We offer to supply in conformity with the Bidding Documents and in accordance with the Delivery Schedules specified in the Schedule of Supply the following Goods and Related Services *[insert a brief description of the Goods and Related Services]*:

(c) The total price of our Bid, excluding any discounts offered in item (d) below is: *[insert the Bid Price in words and figures, indicating the various amounts and their respective currencies]*

(d) The discounts offered and the methodology for their application are:

Discounts. If our Bid is accepted, the following discounts shall apply:

[Specify in detail each discount offered and the specific item of the Schedule of Supply to which it applies.]

Methodology of Application of the Discounts. The discounts shall be applied using the following methodology *[Specify in detail the methodology that shall be used to apply the discounts]:*



- (e) Our Bid shall be valid for a period of *[insert number]*_____ days from the date fixed for the Bid submission deadline in accordance with ITB Sub-Clause 27.1, and it shall remain binding upon us and may be accepted at any time before expiry of that period;
- (f) If our Bid is accepted, we commit to provide a Performance Security in accordance with ITB Clause 47 and GCC Clause 19 for the due performance of the Contract;
- (g) We are not participating, as Bidders, in more than one Bid in this bidding process, other than any alternative offers submitted in accordance with ITB Clause 15;
- (h) We, including any subcontractors or suppliers for any part of the Contract, have nationality from eligible countries, viz: *[insert the nationality of the Bidder, including that of all parties that comprise the Bidder if the Bidder is a JV/C/A, and the nationality each subcontractor and supplier]*_____
- (i) We have no conflict of interest pursuant to ITB Sub-Clause 3.2;
- (j) Our firm, its affiliates or subsidiaries - including any subcontractors or suppliers for any part of the contract - has not been declared ineligible by the Purchaser under the laws or official regulations of Bhutan, in accordance with ITB Sub-Clause 3.4;
- (k) The following commissions, gratuities or fees have been paid or are to be paid with respect to the bidding process or execution of the Contract: *[insert complete name of each Recipient, its full address, the reason for which each commission or gratuity was paid and the amount and currency of each such commission or gratuity]*

Name of Recipient	Address	Reason	Amount
_____	_____	_____	_____
_____	_____	_____	_____

(If none has been paid or is to be paid, indicate “none.”)

- (l) We understand that this Bid, together with your written acceptance thereof included in your notification of award, shall constitute a binding contract between us, until a formal contract is prepared and executed.
- (m) We understand that you are not bound to accept the lowest evaluated Bid or any other Bid that you may receive.

Signed: _____ *[insert signature of person whose name and capacity are shown]*

In the capacity of _____ *[insert legal capacity of person signing the Bid Submission Sheet]*

Name: _____ *[insert complete name of person signing the Bid Submission Sheet]*



Duly authorized to sign the bid for and on behalf of: _____ *[insert complete name of Bidder]*

Dated on _____ day of _____, _____ *[insert date of signing]*



Bid Security (Bank Guarantee)

[The Bank shall fill in this Bank Guarantee Form in accordance with the instructions indicated.]

_____ *[insert Bank's Name, and Address of Issuing Branch or Office]*

Beneficiary: _____ *[Name and Address of Purchaser]*

Date: _____

BID GUARANTEE No.: _____

We have been informed that *[insert name of the Bidder]* (hereinafter called "the Bidder") has submitted to you its Bid dated (hereinafter called "the Bid") for the execution of *[insert name of Contract]* under Invitation for Bids No. *[insert IFB number]* ("the IFB").

Furthermore, we understand that, according to your conditions, Bids must be supported by a Bid Guarantee.

At the request of the Bidder, we *[insert name of Bank]* hereby irrevocably undertake to pay you any sum or sums not exceeding in total an amount of *[insert amount in figures]* (*[insert amount in words]*) upon receipt by us of your first demand in writing accompanied by a written statement stating that the Bidder is in breach of its obligation(s) under the Bid conditions, because the Bidder:

- (a) has withdrawn its Bid during the period of Bid validity specified by the Bidder in the Form of Bid; or
- (b) having been notified of the acceptance of its Bid by the Purchaser during the period of Bid validity,
 - (i) fails or refuses to execute the Contract Form; or (ii) fails or refuses to furnish the Performance Security, if required, in accordance with the Instructions to Bidders.

This guarantee will expire: (a) if the Bidder is the successful Bidder, upon our receipt of copies of the contract signed by the Bidder and the Performance Security issued to you upon the instruction of the Bidder; or (b) if the Bidder is not the successful Bidder, upon the earlier of (i) our receipt of a copy of your notification to the Bidder of the name of the successful Bidder; or (ii) twenty-eight days after the expiration of the Bidder's Bid.

Consequently, any demand for payment under this guarantee must be received by us at this office on or before that date.

[signature(s)]



Manufacturer’s Authorization

[The Bidder shall require the Manufacturer to fill in this Form in accordance with the instructions indicated. This letter of authorization should be on the letterhead of the Manufacturer and be signed by a person with the proper authority to sign documents that are binding on the Manufacturer. The Bidder shall include it in its bid, if so indicated in the BDS.]

Date: _____
Invitation for Bid No.:

To *[insert complete name of the Purchaser]*

WHEREAS

We _____ *[insert complete name of the Manufacturer]*, who are official manufacturers of _____ *[insert type of Goods manufactured]*, having factories at _____ *[insert full address(es) of the Manufacturer’s factory/ies]*, do hereby authorize _____ *[insert complete name of Bidder]* to submit a Bid in relation to the Invitation for Bids indicated above, the purpose of which is to provide the following Goods, manufactured by us, namely _____ *[insert name and/or brief description of the Goods]*, and subsequently to negotiate and sign the Contract.

We hereby extend our full guarantee and warranty in accordance with Clause 29 of the General Conditions of Contract, with respect to the Goods offered by the above firm.

Signed:

Name:

Title:

Duly authorized to sign this Authorization for and on behalf of *[insert complete name of the Bidder]*

Dated on the _____ *[insert number]* day of _____ *[insert month]*, _____ *[insert year]*.



Bill of Quantity (*Bidders can use additional sheets for the service and warranty of items*)

SL.no	Item	Specification	Qty	Rate (Nu)	Amount (Nu)	Remarks
1.	2 Seater Sofa	As per drawing, Figure - 3	2 nos			
2	Arch Sofa	As per drawing, Figure - 4	8 nos			
3	Crecent Sofa	As per drawing, Figure - 5	4 nos			
4	Sectional Sofa	As per drawing, Figure - 6	2 nos			
5	Sofa with Island	As per drawing, Figure - 7	4 nos			
6	Table	As per drawing, Figure - 8	4 nos			
7	Book Rack	As per drawing, Figure – 9	12 nos			

Note:

- Sofa frame should be made of mixed conifer.
- Once the supply order is awarded, the sofa frames will be subject to inspection by the college. Only after the approval of the college, the firm will upholster the sofa.
- The bidders should also submit sample of upholstery material. The colour in the figure is not final. The bidders are free to propose suitable colour along with material sample.
- The bidders should state the thickness and density of the foam.
- Table frame and top should be of rubber wood
- Book rack including the rear panel should be of rubber wood



Name of Bidder _____

Signature of Bidder _____

Date _____

PART 2 – Supply Requirements



Section VI: Schedule of Supply

Contents

1. List of Goods and Delivery Schedule45

2. List of Related Services and Completion Schedule46

3. Technical Specifications47

5. Inspections and Tests48



Notes for Preparing the Schedule of Supply

The Schedule of Supply shall be included in the Bidding Documents by the Purchaser, and shall cover, at a minimum, a description of the Goods and Services to be supplied and the delivery schedule.

The objective of the Schedule of Supply is to provide sufficient information to enable Bidders to prepare their Bids efficiently and accurately, in particular the Price Schedule, for which a form is provided in Section IV. In addition, the Schedule of Supply, together with the Price Schedule, should serve as a basis in the event of quantity variation at the time of award of Contract pursuant to ITB Clause 44.

The date or period for delivery should be carefully specified, taking into account (a) the implications of delivery terms stipulated in the Instructions to Bidders pursuant to the *Incoterms* rules (i.e., EXW; or CIF, CIP, FOB, FCA where “delivery” takes place when the Goods are delivered **to the carriers**), and (b) the date prescribed herein from which the Purchaser’s delivery obligations start (i.e., notice of award, contract signature, opening or confirmation of the letter of credit).



1. List of Goods and Delivery Schedule

[The Purchaser shall fill in this table, with the exception of the column “Bidder’s Offered Delivery Date”, which is to be filled by the Bidder]

Line Item No	Description of Goods	Quantity	Physical unit	Final (Project Site) Destination as specified in BDS	Delivery Date		
					Earliest Delivery Date	Latest Delivery Date	Bidder’s Offered Delivery Date <i>[to be provided by the Bidder]</i>
<i>All the items</i>	<i>As per the price schedule in Section IV</i>	<i>As per the BoQ in price schedule in section IV</i>	<i>As per BoQ in price Schedule in Section IV</i>	<i>College of Science & Technology, Kharbandhi, Phuentsholing, Bhutan</i>	<i>Within 45 days from the date of Purchase order</i>	<i>Within 60 days from the date of purchase order</i>	



2. List of Related Services and Completion Schedule

Service	Description of Service	Quantity¹	Physical Unit	Place where Services shall be performed	Final Completion Date(s) of Services
1.	<i>Installation, testing, commissioning and demonstration cum training to faculties and technician.</i>	<i>As per BOQ</i>	<i>As per BoQ</i>	<i>College of Science & Technology, Kharbndhi, Bhutan</i>	<i>Within 30 days from the date of delivery</i>



3. Technical Specifications

The purpose of the Technical Specifications (TS) is to define the technical characteristics of the Goods and Related Services required by the Purchaser. The Purchaser shall prepare the detailed TS taking into account that:

- *The TS constitute the benchmarks against which the Purchaser will verify the technical responsiveness of Bids and subsequently evaluate the Bids. Therefore, well-defined TS will facilitate preparation of responsive Bids by Bidders, as well as examination, evaluation and comparison of the Bids by the Purchaser.*
- *The TS shall require that all goods and materials to be incorporated in the Goods be new, unused, of the most recent or current models, and that they incorporate all recent improvements in design and materials, unless provided for otherwise in the Contract.*
- *The TS shall make use of best practices. Samples of specifications from successful similar procurements may provide a sound basis for drafting the TS.*
- *Standardizing technical specifications may be advantageous, depending on the complexity of the Goods and the repetitiveness of the type of procurement. Technical Specifications should be broad enough to avoid restrictions on workmanship, materials and equipment commonly used in manufacturing similar kinds of Goods.*
- *Standards for equipment, materials and workmanship specified in the Bidding Documents shall not be restrictive. Recognized international standards should be specified as much as possible. Reference to brand names, catalogue numbers or other details that limit any materials or items to a specific manufacturer should be avoided as far as possible. Where unavoidable, such item description should always be followed by the words “or equivalent or higher.” When other particular standards or codes of practice are referred to in the TS a statement should follow to the effect that other authoritative standards that ensure at least a substantially equal quality will also be acceptable.*
- *Technical Specifications shall be fully descriptive of the requirements in respect of, but not limited to, the following:*
 - (a) *Standards of materials and workmanship required for the production and manufacturing of the Goods.*
 - (b) *Detailed tests required (type and number).*
 - (c) *Other additional work and/or Related Services required to achieve full delivery/completion.*
 - (d) *Detailed activities to be performed by the Supplier, and participation of the Purchaser therein.*
 - (e) *List of detailed functional guarantees covered by the Warranty and the specification of the liquidated damages to be applied in the event that such guarantees are not met.*
- *The TS shall specify all essential technical and performance characteristics and requirements, including guaranteed or acceptable maximum or minimum values, as appropriate. Whenever necessary, the Purchaser shall include an additional ad-hoc bidding form (to be an Attachment to*



the Bid Submission Sheet), where the Bidder shall provide detailed information on such technical performance characteristics in respect of the corresponding acceptable or guaranteed values.

When the Purchaser requests that the Bidder provides in its Bid a part or all of the Technical Specifications, technical schedules or other technical information, the Purchaser shall specify in detail the nature and extent of the required information and the manner in which it has to be presented by the Bidder in its Bid.

[If a summary of the Technical Specifications (TS) has to be provided, the Purchaser shall insert information in the table below. The Bidder shall prepare a similar table to justify compliance with the requirements]

“Summary of Technical Specifications. *The Goods and Related Services shall comply with following Technical Specifications and Standards:*

<i>Item No</i>	<i>Name of Goods or Related Service</i>	<i>Technical Specifications and Standards</i>
<i>All the Items</i>	<i>As in BoQ attached or better goods will be accepted</i>	<ol style="list-style-type: none"> <i>1. As stated in the description of items in BoQ</i> <i>2. Charges on any service as per the incoterm 2015 DDP plus the insurance.</i> <i>3. Damaged items will not be accepted and it should be replaced within 30 days. Bidders are responsible for the damage caused during transaction.</i>

4. Inspections and Tests

The following inspections and tests shall be performed:

- 1. Installation if required*
- 2. Testing of the equipments*
- 3. Demonstration cum training to the staffs if demanded by the purchaser*



PART 3 - CONTRACT



Section VII. General Conditions of Contract

Table of Clauses

1.	Definitions.....	52
2.	Contract Documents.....	53
3.	Fraud and Corruption.....	53
4.	Interpretation.....	54
5.	Language.....	55
6.	Joint Venture, Consortium or Association.....	55
7.	Eligibility.....	56
8.	Notices.....	56
9.	Governing Law.....	56
10.	Settlement of Disputes.....	56
11.	Inspections and Audit.....	57
12.	Scope of Supplies.....	57
13.	Delivery and Documents.....	57
14.	Supplier's Responsibilities.....	57
15.	Purchaser's Responsibilities.....	57
16.	Contract Price.....	57
17.	Terms of Payment.....	58
18.	Taxes and Duties.....	58
19.	Performance Security.....	58
20.	Copyright.....	59
21.	Confidential Information.....	59
22.	Subcontracting.....	60



23	Specifications and Standards	60
24	Packing and Documents	61
25	Insurance	61
26	Transportation	61
27	Inspections and Tests	61
28	Liquidated Damages	62
29	Warranty	62
30	Patent Indemnity.....	63
31	Limitation of Liability.....	64
32	Change in Laws and Regulations.....	64
33	Force Majeure	64
34	Change Orders and Contract Amendments	65
35	Extensions of Time	65
36	Termination	66
37	Assignment.....	67



Section VII. General Conditions of Contract

1. Definitions

- 1.1 The following words and expressions shall have the meanings hereby assigned to them:
- (a) **Award of Contract** means the decision of the Purchaser to enter into a Contract with the Supplier for supply and delivery of the specified Goods, including any Related Services.
 - (b) **Bid** means an offer to supply Goods, including any Related Services, made in accordance with the terms and conditions set out in the Bidding Documents that preceded the placement of the Contract of which these GCC form a part. The term “tender” is synonymous with the term “Bid”.
 - (c) **Bidder** means an eligible individual or legal entity that participated in the bidding process governed by the Bidding Documents that preceded the placement of the Contract of which these GCC form a part.
 - (d) **Bidding Documents** means the set of Bidding Documents that preceded the placement of the Contract of which these GCC form a part, which were sold or issued by the Purchaser to potential Bidders, and in which the specifications, terms and conditions of the proposed procurement were prescribed.
 - (e) **Contract Documents** means the documents listed in the Contract Agreement, including any amendments thereto.
 - (f) **Contract Price** means the price payable to the Supplier as specified in the Contract Agreement, subject to such additions and adjustments thereto or deductions therefrom as may be made pursuant to the Contract.
 - (g) **Day** means calendar day.
 - (h) **Delivery** means the transfer of the Goods from the Supplier to the Purchaser in accordance with the terms and conditions set forth in the Contract Documents.
 - (i) **GCC** means the General Conditions of Contract.
 - (j) **Goods** means all of the commodities, raw materials, machinery and equipment, and/or other materials, including any object in solid, liquid or gaseous form that has an economic utility or value and which can be exchanged or traded, that the Supplier is required to supply to the Purchaser under the Contract.
 - (k) The **Project Site**, where applicable, means the place named in the SCC.
 - (l) **Purchaser** means the entity purchasing the Goods and Related Services, as specified in the SCC.



- (m) **Related Services** means the services incidental to the supply of the Goods, such as insurance, installation, training and initial maintenance and other obligations of the Supplier under the Contract
- (n) **SCC** means the Special Conditions of Contract.
- (o) **Subcontractor** means any natural person, private or government entity, or a combination thereof, including its legal successors and permitted assigns, to whom any part of the Goods to be supplied or execution of any part of the Related Services is subcontracted by the Supplier.
- (p) **Supplier** means the natural person, private or government entity, or a combination of the above, whose Bid to perform the Contract has been accepted by the Purchaser and is named as such in the Agreement, and includes the legal successors or permitted assigns of the Supplier.

2. Contract Documents

- 2.1 Subject to the order of precedence set forth in the Contract Agreement, all documents forming the Contract (and all parts thereof) are intended to be correlative, complementary and mutually explanatory. The Contract Agreement shall be read as a whole.

3. Fraud and Corruption

- 3.1 If the Purchaser determines that the Supplier has engaged in corrupt, fraudulent, collusive, coercive or obstructive practices in competing for or in executing the Contract then the Purchaser may, after giving fourteen (14) days notice to the Supplier, terminate the Supplier's employment under the Contract and cancel the Contract, and the provisions of GCC Clause 36 shall apply as if such termination has been made under GCC Sub-Clause 36.1.
- 3.2 Should any employee of the Supplier be determined to have engaged in corrupt, fraudulent, collusive, coercive or obstructive practice during the purchase of the Goods, then that employee shall be removed.
- 3.3 For the purposes of this Sub-Clause:
- (a) “corrupt practice”⁸ is the offering, giving, receiving or soliciting, directly or indirectly, of anything of value⁹ to influence improperly the actions of another party;
- (b) “fraudulent practice”¹⁰ is any intentional act or omission, including a misrepresentation, that knowingly or recklessly misleads, or attempts to mislead, a party to obtain a

⁸ “another party” refers to a public official acting in relation to the procurement process or contract execution. In this context, “public official” includes staff and employees of other organizations (including any institutions providing finance for the Goods) taking or reviewing procurement decisions.

⁹ “anything of value” includes, but is not limited to, any gift, loan, fee, commission, valuable security or other asset or interest in an asset; any office, employment or contract; any payment, discharge or liquidation of any loan, obligation or other liability whatsoever, whether in whole or in part; any other services, favour or advantage, including protection from any penalty or disability incurred or apprehended or from any action or proceeding of a disciplinary or penal nature, whether or not already instituted and including the exercise or the forbearance from the exercise of any right or any official power or duty.



<p>financial or other benefit or to avoid an obligation;</p> <p>(c) “collusive practice”¹¹ is an arrangement between two or more parties designed to achieve an improper purpose, including to influence improperly the actions of another party;</p> <p>(d) “coercive practice”¹² is impairing or harming, or threatening to impair or harm, directly or indirectly, any party or the property of the party to influence improperly the actions of a party;</p> <p>(e) “obstructive practice” is</p> <p>(i) deliberately destroying, falsifying, altering or concealing of evidence material to the investigation or making false statements to investigators in order materially to impede any investigation into allegations of a corrupt, fraudulent, coercive or collusive practice; and/or threatening, harassing or intimidating any party to prevent it from disclosing its knowledge of matters relevant to the investigation or from pursuing the investigation; or</p> <p>(ii) acts intended materially to impede the exercise of the inspection and audit rights of the Purchaser and/or any other relevant RGoB agency provided for under GCC Clause 11.</p> <p>3.4 Any communications between the Supplier and the Purchaser related to matters of alleged fraud or corruption must be made in writing.</p>
<p>4 Interpretation</p> <p>4.1 If the context so requires it, singular means plural and vice versa.</p> <p>4.2 Incoterms</p> <p>(a) Unless inconsistent with any provision of the Contract or otherwise specified in the SCC, the meaning of any trade term and the rights and obligations of parties thereunder shall be as prescribed by Incoterms.</p> <p>(b) The terms EXW, CIF, CIP and other similar terms, when used, shall be governed by the rules prescribed in the current edition of Incoterms specified in the SCC and published by the International Chamber of Commerce in Paris, France.</p> <p>4.3 Entire Agreement</p> <p>The Contract constitutes the entire agreement between the Purchaser and the Supplier and</p>

¹⁰ a “party” refers to a public official; the terms “benefit” and “obligation” relate to the procurement process or contract execution; and the “act or omission” is intended to influence the procurement process or contract execution.

¹¹ “parties” refers to participants in the procurement process (including public officials) and an “improper purpose” includes attempting to establish bid prices at artificial, non competitive levels.

¹² a “party” refers to a participant in the procurement process or contract execution.



supersedes all communications, negotiations and agreements (whether written or oral) of the parties with respect thereto made prior to the date of Contract.

4.4 Amendment

No amendment or other variation of the Contract shall be valid unless it is in writing, is dated, expressly refers to the Contract, and is signed by a duly authorized representative of each party thereto.

4.5 Non-waiver

- (a) Subject to GCC Sub-Clause 4.5 (b) below, no relaxation, forbearance, delay or indulgence by either party in enforcing any of the terms and conditions of the Contract or the granting of time by either party to the other shall prejudice, affect or restrict the rights of that party under the Contract, neither shall any waiver by either party of any breach of Contract operate as waiver of any subsequent or continuing breach of Contract.
- (b) Any waiver of a party's rights, powers or remedies under the Contract must be in writing, dated and signed by an authorized representative of the party granting such waiver, and must specify the right and the extent to which it is being waived.

4.6 Severability

If any provision or condition of the Contract is prohibited or rendered invalid or unenforceable, such prohibition, invalidity or unenforceability shall not affect the validity or enforceability of any other provisions and conditions of the Contract.

5 Language

- 5.1 The Contract, as well as all correspondence and documents relating to the Contract exchanged by the Supplier and the Purchaser, shall be written in the language specified in the SCC. Supporting documents and printed literature that are part of the Contract may be in another language provided they are accompanied by an accurate translation of the relevant passages in the language specified in the SCC, in which case, for purposes of interpretation of the Contract, the translation shall govern.
- 5.2 The Supplier shall bear all costs of translation to the governing language and all risks of the accuracy of such translation, for documents provided by the Supplier.

6 Joint Venture, Consortium or Association

- 6.1 If the Supplier is a joint venture, consortium or association, all of the parties shall be jointly and severally liable to the Purchaser for the fulfillment of the provisions of the Contract and shall designate one party to act as a leader with authority to bind the joint venture, consortium or association. The composition or the constitution of the joint venture, consortium or association shall not be altered without the prior consent of the Purchaser.



7 Eligibility

- 7.1 The Supplier and its Subcontractors shall have the nationality of an eligible country. A Supplier or Subcontractor shall be deemed to have the nationality of a country if it is a citizen or constituted, incorporated, or registered, and operates in conformity with the provisions of the laws of that country.
- 7.2 All Goods and Related Services to be supplied under the Contract shall have their origin in Eligible Countries. For the purpose of this Clause, origin means the country where the Goods have been grown, mined, cultivated, produced, manufactured or processed; or through manufacture, processing or assembly, another commercially recognized article results that differs substantially in its basic characteristics from its components.

8 Notices

- 8.1 Any notice given by one party to the other pursuant to the Contract shall be in writing to the address specified in the SCC. The term “in writing” means communicated in written form, including electronic communication, with proof of receipt.
- 8.2 A notice shall be effective when delivered or on the notice’s effective date, whichever is later.

9 Governing Law

- 9.1 The Contract shall be governed by and interpreted in accordance with the laws of Bhutan.

10 Settlement of Disputes

- 10.1 The Purchaser and the Supplier shall make every effort to resolve amicably by direct informal negotiation any disagreement or dispute arising between them under or in connection with the Contract.
- 10.2 If, after thirty (30) days, the parties have failed to resolve their dispute or difference by such mutual consultation, either the Purchaser or the Supplier may give notice to the other party of its intention to commence arbitration, as hereinafter provided, as to the matter in dispute. No arbitration in respect of this matter may be commenced unless such notice is given. Any dispute or difference in respect of which a notice of intention to commence arbitration has been given in accordance with this Clause shall be finally settled by arbitration. Arbitration may be commenced prior to or after delivery of the Goods under the Contract. Arbitration proceedings shall be conducted in accordance with the rules of procedure specified in the SCC.
- 10.3 Notwithstanding any reference to arbitration herein,
- (a) the parties shall continue to perform their respective obligations under the Contract unless they otherwise agree; and
 - (b) the Purchaser shall pay the Supplier any monies due the Supplier.



11 Inspections and Audit

11.1 The Supplier shall permit the Purchaser and/or persons appointed by the Purchaser to inspect the Supplier's offices and/or the accounts and records of the Supplier and its Subcontractors relating to the performance of the Contract, and to have such accounts and records audited by auditors appointed by the Purchaser if so required by the Purchaser. The Supplier's attention is drawn to GCC Clause 3, which provides, inter alia, that acts intended materially to impede the exercise of the inspection and audit rights provided for under this GCC Sub-Clause 11.1 constitute a prohibited practice subject to contract termination (as well as to a determination of ineligibility under ITB Sub-Clause 2.1 (c) of the Instructions to Bidders that preceded the placement of the Contract of which these GCC form a part).

12 Scope of Supplies

12.1 The Goods and Related Services to be supplied shall be as specified in the Schedule of Supply.

12.2 Unless otherwise stipulated in the Contract, the Supply shall include all such items not specifically mentioned in the Contract but that can be reasonably inferred from the Contract as being required for attaining Delivery of the Goods and Completion of the Related Services as if such items were expressly mentioned in the Contract.

13 Delivery and Documents

13.1 Subject to GCC Sub-Clause 34.1, the delivery of the Goods and completion of the Related Services shall be in accordance with the delivery and completion requirements specified in the Schedule of Supply. The details of shipping and other documents to be furnished by the Supplier are specified in the SCC.

14 Supplier's Responsibilities

14.1 The Supplier shall supply all the Goods and Related Services included in the Scope of Supplies in accordance with GCC Clause 12, and the delivery and completion requirements as per GCC Clause 13.

15 Purchaser's Responsibilities

15.1 Whenever the supply of Goods and Related Services requires that the Supplier obtain permits, approvals and/or import and other licenses or similar permissions from Bhutanese public authorities, the Purchaser shall, if so required by the Supplier, use its best efforts to assist the Supplier in complying with such requirements in a timely and expeditious manner, but without incurring any costs.

16 Contract Price

16.1 The Contract Price shall be as specified in the Contract Agreement subject to any additions and adjustments thereto or deductions therefrom as may be made pursuant to the Contract.

16.2 Prices charged by the Supplier for the Goods supplied and the Related Services performed



under the Contract shall not vary from the prices quoted by the Supplier in its Bid, with the exception of any price adjustments authorized in the SCC.

17 Terms of Payment

- 17.1 The Contract Price, including any Advance Payments, if applicable, shall be paid as specified in the SCC.
- 17.2 The Supplier's request for payment shall be made to the Purchaser in writing, accompanied by invoices describing, as appropriate, the Goods delivered and Related Services performed, and by the documents submitted pursuant to GCC Clause 13 and upon fulfillment of all the obligations stipulated in the Contract.
- 17.3 Payments shall be made promptly by the Purchaser, no later than thirty (30) days after the submission of verified invoice or request for payment by the Supplier, and the Purchaser has accepted it.
- 17.4 The currencies in which payments shall be made to the Supplier under this Contract shall be those in which the Bid Price is expressed.
- 17.5 In the event that the Purchaser fails to pay the Supplier any payment by its due date or within the period set forth in the SCC, the Purchaser shall pay to the Supplier interest on the amount of such delayed payment at the rate shown in the SCC, for the period of delay until payment has been made in full, whether before or after judgment or arbitrage award.

18 Taxes and Duties

- 18.1 For Goods manufactured outside Bhutan the Supplier shall bear and pay all applicable taxes, stamp duties, licence fees and other similar levies imposed outside Bhutan.
- 18.2 For Goods manufactured within Bhutan the Supplier shall bear and promptly pay all applicable taxes, duties, licence fees and other similar levies incurred until delivery of the contracted Goods to the Purchaser.
- 18.3 If any tax exemptions, reductions, allowances or privileges may be available to the Supplier in Bhutan the Purchaser shall use its best efforts to enable the Supplier to benefit from any such tax savings to the maximum allowable extent.

19 Performance Security

- 19.1 The Supplier shall, within fifteen (15) working days of the notification of contract award, provide a Performance Security for the due performance of the Contract in the amount and currency specified in the SCC.
- 19.2 The proceeds of the Performance Security shall be payable to the Purchaser as compensation for any loss resulting from the Supplier's failure to complete its obligations under the Contract.



19.3 The Performance Security shall be denominated in the currency(ies) of the Contract, or in a freely convertible currency acceptable to the Purchaser, shall be valid until the successful completion of the Supplier's performance obligations under the Contract, including any warranty obligations, and shall be in one of the forms stipulated by the Purchaser in the SCC.

19.4 The Performance Security shall be discharged by the Purchaser and returned to the Supplier not later than thirty (30) days following the date of completion of the Supplier's performance obligations under the Contract, including any warranty obligations, unless specified otherwise in the SCC,.

20 Copyright

20.1 The copyright in all drawings, documents and other materials containing data and information furnished to the Purchaser by the Supplier shall remain vested in the Supplier, or, if they are furnished to the Purchaser directly or through the Supplier by any third party, including suppliers of materials, the copyright in such materials shall remain vested in such third party.

21 Confidential Information

21.1 The Purchaser and the Supplier shall keep confidential and shall not, without the written consent of the other party hereto, divulge to any third party any documents, data or other information furnished directly or indirectly by the other party hereto in connection with the Contract, whether such information has been furnished prior to, during or following completion or termination of the Contract. Notwithstanding the above, the Supplier may furnish to its Subcontractor(s) such documents, data and other information as it receives from the Purchaser to the extent required for the Subcontractor(s) to perform its/their work under the Contract, in which event the Supplier shall obtain from such Subcontractor(s) an undertaking of confidentiality similar to that imposed on the Supplier under GCC Clause 21.

21.2 The Purchaser shall not use such documents, data and other information received from the Supplier for any purposes unrelated to the Contract. Similarly, the Supplier shall not use such documents, data and other information received from the Purchaser for any purpose other than the design, procurement or other work and services required for the performance of the Contract.

21.3 The obligation of a party under GCC Sub-Clauses 21.1 and 21.2 above, however, shall not apply to information that:

- (a) the Purchaser or Supplier needs to share with the RGoB or other institutions participating in the financing of the Contract;



- (b) now or hereafter enters the public domain through no fault of that party;
- (c) can be proven to have been possessed by that party at the time of disclosure and which was not previously obtained, directly or indirectly, from the other party; or
- (d) otherwise lawfully becomes available to that party from a third party that has no obligation of confidentiality.

21.4 The above provisions of GCC Clause 21 shall not in any way modify any undertaking of confidentiality given by either of the parties hereto prior to the date of the Contract in respect of the Supply or any part thereof.

21.5 The provisions of GCC Clause 21 shall survive completion or termination, for whatever reason, of the Contract.

22 Subcontracting

22.1 The Supplier shall notify the Purchaser in writing of all subcontracts awarded under the Contract if not already specified in the Bid. Such notification, in the original Bid or later, shall not relieve the Supplier of any of its obligations, duties, responsibilities or liabilities under the Contract.

22.2 Subcontracts shall comply with the provisions of GCC Clauses 3 and 7.

23 Specifications and Standards

23.1 Technical Specifications and Drawings:

- (a) The Goods and Related Services supplied under this Contract shall conform to the technical specifications and standards stipulated in Section VI, Schedule of Supply and, when no applicable standard is mentioned, the standard shall be equivalent or superior to the official standards whose application is appropriate to the Goods' country of origin.
- (b) The Supplier shall be entitled to disclaim responsibility for any design, data, drawing, specification or other document, or any modification thereof provided or designed by or on behalf of the Purchaser, by giving a notice of such disclaimer to the Purchaser.
- (c) Wherever references are made in the Contract to codes and standards in accordance with which it shall be executed, the editions or the revised versions of such codes and standards shall be those specified in the Schedule of Supply.



During Contract execution, any changes in any such codes and standards shall be applied only after approval by the Purchaser and shall be treated in accordance with GCC Clause 34.

24 Packing and Documents

- 24.1 The Supplier shall provide such packing of the Goods as is required to prevent their damage or deterioration during transit to their final destination, as indicated in the Contract. During transit, the packing shall be sufficient to withstand, without limitation, rough handling and exposure to extreme temperatures, salt and precipitation, and open storage. Packing case sizes and weights shall take into consideration, where appropriate, the remoteness of the Goods' final destination and the absence of heavy handling facilities at all points in transit.
- 24.2 The packing, marking and documentation within and outside the packages shall comply strictly with such special requirements as shall be expressly provided for in the Contract, including additional requirements, if any, specified in the SCC, and in any other instructions ordered by the Purchaser.

25 Insurance

- 25.1 Unless otherwise specified in the SCC the Goods supplied under the Contract shall be fully insured, in a freely convertible currency from an eligible country, against loss or damage incidental to manufacture or acquisition, transportation, storage and delivery, in accordance with the applicable Incoterms or in the manner specified in the SCC.

26 Transportation

- 26.1 Unless otherwise specified in the SCC, responsibility for arranging transportation of the Goods shall be in accordance with the specified Incoterms.

27 Inspections and Tests

- 27.1 At its own expense and at no cost to the Purchaser the Supplier shall carry out all such tests and/or inspections of the Goods and Related Services as are specified in the SCC.
- 27.2 The inspections and tests may be conducted on the premises of the Supplier or its Subcontractor, at point of delivery, and/or at the Goods' final destination, or in another place in Bhutan as specified in the SCC. Subject to GCC Sub-Clause 27.3, if conducted on the premises of the Supplier or its Subcontractor, all reasonable facilities and assistance, including access to drawings and production data, shall be furnished to the inspectors at no charge to the Purchaser.
- 27.3 The Purchaser or its designated representative shall be entitled to attend the tests and/or inspections referred to in GCC Sub-Clause 27.2, provided that the Purchaser bears all of its own costs and expenses incurred in connection with such attendance including, but not limited to, all travelling and board and lodging expenses.
- 27.4 Whenever the Supplier is ready to carry out any such test and inspection, it shall give



reasonable advance notice, including the place and time, to the Purchaser. The Supplier shall obtain from any relevant third party or manufacturer any necessary permission or consent to enable the Purchaser or its designated representative to attend the test and/or inspection.

- 27.5 The Purchaser may require the Supplier to carry out any test and/or inspection not required by the Contract but deemed necessary to verify that the characteristics and performance of the Goods comply with the technical specifications, codes and standards under the Contract, provided that the Supplier's reasonable costs and expenses incurred in the carrying out of such test and/or inspection shall be added to the Contract Price. Further, if such test and/or inspection impedes the progress of manufacturing and/or the Supplier's performance of its other obligations under the Contract, due allowance will be made in respect of the Delivery Dates and Completion Dates and the other obligations so affected.
- 27.6 The Supplier shall provide the Purchaser with a report of the results of any such test and/or inspection.
- 27.7 The Purchaser may reject any Goods or any part thereof that fail to pass any test and/or inspection or do not conform to the specifications. The Supplier shall either rectify or replace such rejected Goods or parts thereof or make alterations necessary to meet the specifications at no cost to the Purchaser, and shall repeat the test and/or inspection, at no cost to the Purchaser, upon giving a notice pursuant to GCC Sub-Clause 27.4.
- 27.8 The Supplier agrees that neither the execution of a test and/or inspection of the Goods or any part thereof, nor the attendance by the Purchaser or its representative, nor the issue of any report pursuant to GCC Sub-Clause 27.6, shall release the Supplier from any warranties or other obligations under the Contract.

28 Liquidated Damages

- 28.1 Except as provided for under GCC Clause 33, if the Supplier fails to deliver any or all of the Goods by the date(s) of delivery or fails to perform the Related Services within the period specified in the Contract, the Purchaser may, without prejudice to all its other remedies under the Contract, deduct from the Contract Price, as liquidated damages, a sum equivalent to the percentage specified in the SCC of the delivered price of the delayed Goods or unperformed Services for each week or part thereof of delay until actual delivery or performance, up to a maximum deduction of the percentage specified in those SCC. Once the maximum is reached, the Purchaser may terminate the Contract pursuant to GCC Clause 36.

29 Warranty

- 29.1 The Supplier warrants that all the Goods are new, unused, and of the most recent or current models, and that they incorporate all recent improvements in design and materials, unless provided otherwise in the Contract.
- 29.2 Subject to GCC Sub-Clause 23.1 (b), the Supplier further warrants that the Goods shall be free from defects arising from any act or omission of the Supplier or arising from design,



materials and workmanship, under normal use in the conditions prevailing in Bhutan.

- 29.3 Unless otherwise specified in the SCC, the warranty shall remain valid for twelve (12) months after the Goods, or any portion thereof as the case may be, have been delivered to and accepted at the final destination indicated in the SCC, or for eighteen (18) months after the date of shipment from the port or place of loading in the country of origin, whichever period concludes earlier.
- 29.4 The Purchaser shall give notice to the Supplier stating the nature of any such defects together with all available evidence thereof, promptly following the discovery thereof. The Purchaser shall afford all reasonable opportunity for the Supplier to inspect such defects.
- 29.6 Upon receipt of such notice, the Supplier shall, within the period specified in the SCC, expeditiously repair or replace the defective Goods or parts thereof, at no cost to the Purchaser.
- 29.7 If, having been notified, the Supplier fails to remedy the defect within the period specified in the SCC, the Purchaser may proceed to take within a reasonable period such remedial action as may be necessary, at the Supplier's risk and expense and without prejudice to any other rights which the Purchaser may have against the Supplier under the Contract.

30 Patent Indemnity

- 30.1 The Supplier shall, subject to the Purchaser's compliance with GCC Sub-Clause 30.2, indemnify and hold harmless the Purchaser and its employees and officers from and against any and all suits, actions or administrative proceedings, claims, demands, losses, damages, costs and expenses of any nature, including attorney's fees and expenses, which the Purchaser may suffer as a result of any infringement or alleged infringement of any patent, utility model, registered design, trademark, copyright or other intellectual property right registered or otherwise existing at the date of the Contract by reason of:
- a) the installation of the Goods by the Supplier or the use of the Goods in Bhutan; and
 - b) the sale in any country of the products produced by the Goods.
- Such indemnity shall not cover any use of the Goods or any part thereof other than for the purpose indicated by or reasonably to be inferred from the Contract, neither any infringement resulting from the use of the Goods or any part thereof, or any products produced thereby in association or combination with any other equipment, plant or materials not supplied by the Supplier, pursuant to the Contract.
- 30.2 If any proceedings are brought or any claim is made against the Purchaser arising out of the matters referred to in GCC Sub-Clause 30.1, the Purchaser shall promptly give the Supplier notice thereof, and the Supplier may at its own expense and in the Purchaser's name conduct such proceedings or claim and any negotiations for the settlement of any such proceedings or claim.
- 30.3 If the Supplier fails to notify the Purchaser within thirty (30) days after receipt of such notice that it intends to conduct any such proceedings or claim, then the Purchaser shall be



free to conduct the same on its own behalf.

30.4 The Purchaser shall, at the Supplier's request, afford all available assistance to the Supplier in conducting such proceedings or claim, and shall be reimbursed by the Supplier for all reasonable expenses incurred in so doing.

30.6 The Purchaser shall indemnify and hold harmless the Supplier and its employees, officers and Subcontractors from and against any and all suits, actions or administrative proceedings, claims, demands, losses, damages, costs and expenses of any nature, including attorney's fees and expenses, which the Supplier may suffer as a result of any infringement or alleged infringement of any patent, utility model, registered design, trademark, copyright or other intellectual property right registered or otherwise existing at the date of the Contract arising out of or in connection with any design, data, drawing, specification or other documents or materials provided or designed by or on behalf of the Purchaser.

31 Limitation of Liability

31.1 Except in cases of gross negligence or willful misconduct:

(a) neither party shall be liable to the other party, whether in contract, tort or otherwise, for any indirect or consequential loss or damage, loss of use, loss of production, or loss of profits or interest costs, provided that this exclusion shall not apply to any obligation of the Supplier to pay liquidated damages to the Purchaser; and

(b) the aggregate liability of the Supplier to the Purchaser, whether under the Contract, in tort or otherwise, shall not exceed the total Contract Price, provided that this limitation shall not apply to the cost of repairing or replacing defective equipment, or to any obligation of the Supplier to indemnify the Purchaser with respect to patent infringement.

32 Change in Laws and Regulations

32.1 Unless otherwise specified in the Contract if, after the date thirty (30) days prior to the date of Bid submission, any law, regulation, ordinance, order or bylaw having the force of law is enacted, promulgated, abrogated or changed in Bhutan (which shall be deemed to include any change in interpretation or application by the competent authorities) that subsequently affects the Delivery/Completion Schedule and/or the Contract Price, then such Delivery/Completion Schedule and/or Contract Price shall be correspondingly increased or decreased, to the extent that the Supplier has thereby been affected in the performance of any of its obligations under the Contract. Notwithstanding the foregoing, such additional or reduced cost shall not be separately paid or credited if the same has already been accounted for in the price adjustment provisions where applicable, in accordance with GCC Sub-Clause 16.2.

33 Force Majeure

33.1 The Supplier shall not be liable for forfeiture of its Performance Security, liquidated



damages or termination for default if and to the extent that its delay in performance or other failure to perform its obligations under the Contract is the result of an event of Force Majeure.

- 33.2 For purposes of this Clause, “Force Majeure” means an event or situation beyond the control of the Supplier that is not foreseeable, is unavoidable, and its origin is not due to negligence or lack of care on the part of the Supplier. Such events may include, but not be limited to, acts of the Purchaser in its sovereign capacity, wars or revolutions, fires, floods, epidemics, quarantine restrictions and freight embargoes.
- 33.3 If a Force Majeure situation arises, the Supplier shall promptly notify the Purchaser in writing of such condition and the cause thereof. Unless otherwise directed by the Purchaser in writing, the Supplier shall continue to perform its obligations under the Contract as far as is reasonably practical, and shall seek all reasonable alternative means for performance not prevented by the Force Majeure event.

34 Change Orders and Contract Amendments

- 34.1 The Purchaser may at any time order the Supplier through notice in accordance with GCC Clause 8 to make changes within the general scope of the Contract in any one or more of the following:
- (a) drawings, designs or specifications, where Goods to be furnished under the Contract are to be specifically manufactured for the Purchaser;
 - (b) the method of shipment or packing;
 - (c) the place of delivery; and
 - (d) the Related Services to be provided by the Supplier.
- 34.2 If any such change causes an increase or decrease in the cost of, or the time required for, the Supplier’s performance of any provisions under the Contract, an equitable adjustment shall be made in the Contract Price or in the Delivery/Completion Schedule, or both, and the Contract shall accordingly be amended. Any claims by the Supplier for adjustment under this Clause must be asserted within thirty (30) days from the date of the Supplier’s receipt of the Purchaser’s change order.
- 34.3 Prices to be charged by the Supplier for any Related Services that might be needed but which were not included in the Contract shall be agreed upon in advance by the parties and shall not exceed the prevailing rates charged to other parties by the Supplier for similar services.
- 34.4 Subject to the above, no variation in or modification of the terms of the Contract shall be made except by written amendment by the parties.

35 Extensions of Time

- 35.1 If at any time during performance of the Contract the Supplier or its subcontractors should



encounter conditions impeding timely delivery of the Goods or completion of Related Services pursuant to GCC Clause 13, the Supplier shall promptly notify the Purchaser in writing of the delay, its likely duration, and its cause. As soon as practicable after receipt of the Supplier's notice, the Purchaser shall evaluate the situation and may at its discretion extend the Supplier's time for performance, in which case the extension shall be ratified by the parties by amendment of the Contract.

- 35.2 Except in case of Force Majeure, as provided under GCC Clause 33, a delay by the Supplier in the performance of its Delivery and Completion obligations shall render the Supplier liable to the imposition of liquidated damages pursuant to GCC Clause 28, unless an extension of time is agreed upon, pursuant to GCC Sub-Clause 35.1.

36 Termination

36.1 Termination for Default

- (a) The Purchaser, without prejudice to any other remedy for breach of Contract, by written notice of default sent to the Supplier, may terminate the Contract in whole or in part:
- (i) if the Supplier fails to deliver any or all of the Goods within the period specified in the Contract, or within any extension thereof granted by the Purchaser pursuant to GCC Sub-Clause 35.1; or
 - (ii) if the Supplier fails to perform any other obligation under the Contract; or
 - (iii) if the Supplier, in the judgment of the Purchaser has engaged in fraud and corruption, as defined in GCC Clause 3, in competing for or in executing the Contract.
- (b) In the event the Purchaser terminates the Contract in whole or in part, pursuant to GCC Clause 36.1(a), the Purchaser may procure, upon such terms and in such manner as it deems appropriate, Goods or Related Services similar to those undelivered or not performed, and the Supplier shall be liable to the Purchaser for any additional costs for such similar Goods or Related Services. However, the Supplier shall continue performance of the Contract to the extent not terminated.

36.2 Termination for Insolvency

The Purchaser may at any time terminate the Contract by giving notice to the Supplier if the Supplier becomes bankrupt or otherwise insolvent. In such event, termination shall be without compensation to the Supplier, provided that such termination shall not prejudice or affect any right of action or remedy that has accrued or will accrue thereafter to the Purchaser.

36.3 Termination for Convenience.

- (a) The Purchaser, by notice sent to the Supplier, may terminate the Contract, in whole or in part, at any time for its convenience. The notice of termination shall specify that termination is for the Purchaser's convenience, the extent to which performance of



the Supplier under the Contract is terminated, and the date upon which such termination becomes effective.

- (b) The Goods that are complete and ready for shipment within thirty (30) days after the Supplier's receipt of notice of termination shall be accepted by the Purchaser at the Contract terms and prices. For the remaining Goods, the Purchaser may elect:
- (i) to have any portion completed and delivered at the Contract terms and prices; and/or
 - (ii) to cancel the remainder and pay to the Supplier an agreed amount for partially completed Goods and Related Services and for materials and parts previously procured by the Supplier.

37 Assignment

- 37.1 Neither the Purchaser nor the Supplier shall assign, in whole or in part, their obligations under this Contract, except with the prior written consent of the other party.

38. Export Restriction

- 38.1 Notwithstanding any obligation under the Contract to complete all export formalities, any export restrictions attributable to the Purchaser, to Bhutan, or to the use of the products/Goods, systems or services to be supplied, which arise from trade regulations from a country supplying those products/Goods, systems or services, and which substantially impede the Supplier from meeting its obligations under the Contract, shall release the Supplier from the obligation to provide deliveries or services, always provided, however, that the Supplier can demonstrate to the satisfaction of the Purchaser that it has completed all formalities in a timely manner, including applying for permits, authorizations and licenses necessary for the export of the products/Goods, systems or services under the terms of the Contract. Termination of the Contract on this basis shall be for the Purchaser's convenience pursuant to Sub-Clause 36.3.



Section VIII. Special Conditions of Contract	
The following Special Conditions of Contract (SCC) shall supplement and/or amend the General Conditions of Contract (GCC). Whenever there is a conflict, the provisions herein shall prevail over those in the GCC. <i>[The Purchaser shall select and insert the appropriate wording using the sample below or other acceptable wording and delete the text in italics.]</i>	
1.1 (k) The Project Site(s)/Final Destination(s) is: <i>College of Science and Technology, Kharbandhi, Rinchendhing, Phuentsholing, Bhutan</i>	
1.1 (l)	The Purchaser is: <i>President, College of Science and Technology</i>
GCC 4.2 (a)	The meaning of the trade terms shall be as prescribed by Incoterms. If the meaning of any trade term and the rights and obligations of the parties thereunder shall not be as prescribed by Incoterms, they shall be as prescribed by: <i>exceptional; refer to other internationally accepted trade terms</i>
GCC 4.2 (b)	The version of Incoterms shall be: <i>DDP (2015 version)</i>
GCC 5.1	The language shall be: <i>English</i>
GCC 8.1	For notices , the addresses shall be: For the Purchaser: Attention: <i>ADM Officer</i> Address: <i>College of Science & Technology, Kharbandhi, Post Box # 450, Phuentsholing, Bhutan</i> Telephone: <i>+975-5-17160538</i> E-mail address: <i>schoden.cst@rub.edu.bt</i>
GCC 9	The governing law shall be <u>the law of the Kingdom of Bhutan (Procurement Rules and Regulation of Bhutan)</u> .
GCC 10.2	The rules of procedure for arbitration proceedings pursuant to GCC Sub-Clause 10.2 shall be as follows: <i>[The Bidding Documents should contain one clause to be retained in the event of a Contract with a foreign Supplier and one clause to be retained in the event of a Contract with a Bhutanese Supplier. At the time of finalizing the Contract, the respective applicable clause should be retained in the Contract. The following</i>



	<p><i>explanatory note should therefore be inserted as a header to GCC Sub-Clause 10.2 in the Bidding Documents.</i></p> <p><i>“Clause 10.2 (a) shall be retained in the case of a Contract with a foreign Supplier and Clause 10.2 (b) shall be retained in the case of a Contract with a Bhutanese Supplier.”]</i></p> <p><i>If the Purchaser chooses the UNCITRAL Arbitration Rules, the following sample clause should be inserted:</i></p> <p>GCC 10.2 (a)—Any dispute, controversy or claim arising out of or relating to this Contract, or breach, termination or invalidity thereof, shall be settled by arbitration in accordance with the UNCITRAL Arbitration Rules as at present in force.</p> <p><i>If the Purchaser chooses the Rules of ICC, the following sample clause should be inserted:</i></p> <p>GCC 10.2 (a)—All disputes arising in connection with the present Contract shall be finally settled under the Rules of Conciliation and Arbitration of the International Chamber of Commerce by one or more arbitrators appointed in accordance with the said Rules.</p> <p><i>If the Purchaser chooses the Rules of the Arbitration Institute of the Stockholm Chamber of Commerce, the following sample clause should be inserted:</i></p> <p>GCC 10.2 (a)—Any dispute, controversy or claim arising out of or in connection with this Contract, or the breach, termination or invalidity thereof, shall be settled by arbitration in accordance with the Rules of the Arbitration Institute of the Stockholm Chamber of Commerce.</p>
	<p><i>If the Purchaser chooses the Rules of the London Court of International Arbitration, the following clause should be inserted:</i></p> <p>GCC 10.2 (a)—Any dispute arising out of or in connection with this Contract, including any question regarding its existence, validity or termination shall be referred to and finally resolved by arbitration under the Rules of the London Court of International Arbitration, which rules are deemed to be incorporated by reference to this clause.</p> <p><i>(b) Contract with a Bhutanese Supplier:</i></p> <p>In the case of a dispute between the Purchaser and a Bhutanese Supplier, the dispute shall be referred to adjudication or arbitration in accordance with the laws of Bhutan.</p>
GCC 13.1	<p>Details of Shipping and other Documents to be furnished by the Supplier are <i>insert the required documents, such as a negotiable bill of lading, a non negotiable sea way bill, an airway bill, a railway consignment note, a road consignment note, insurance certificate, Manufacturer’s or Supplier’s warranty certificate, inspection certificate issued by nominated inspection agency, Supplier’s factory shipping</i></p>



	<p>details etc].</p> <p>The above documents shall be received by the Purchaser before arrival of the Goods and, if not received, the Supplier will be responsible for any consequent expenses.</p>
GCC 16.2	<p>The prices charged for the Goods supplied and the related Services performed <i>shall not</i> be adjustable.</p> <p>If prices are adjustable, the following method shall be used to calculate the price adjustment [see attachment to these SCC for a sample Price Adjustment Formula]</p>
GCC 17.1	<p>Sample provision</p> <p>GCC 17.1—The method and conditions of payment to be made to the Supplier under this Contract shall be as follows:</p> <p>Payment for Goods supplied from abroad:</p> <p>Payment of the foreign currency portion shall be made in (None</p> <p>(i) Advance Payment: Ten percent (10%) of the Contract Price shall be paid within thirty (30) days of signing of the Contract, and upon submission of a claim and an advance payment guarantee for the equivalent amount valid until the Goods are delivered and in the form provided in the Bidding Documents.</p>
	<p>(ii) On Shipment: Eighty percent (80%) of the Contract Price of the Goods shipped shall be paid through irrevocable confirmed letter of credit opened in favor of the Supplier in a bank in its country, upon submission of the documents specified in GCC Clause 13.</p> <p>(iii) On Acceptance: Ten percent (10%) of the Contract Price of the Goods received shall be paid within thirty (30) days of receipt of the Goods upon submission of claim supported by the acceptance certificate issued by the Purchaser.</p> <p>Payment of the local currency portion shall be made in Bhutanese Ngultrum (BTN) within thirty (30) days of presentation of a claim supported by a certificate from the Purchaser declaring that the Goods have been delivered and that all other contracted Services have been performed.</p> <p>Payment for Goods and Services supplied from within Bhutan:</p> <p>Payment for Goods and Services supplied from within Bhutan shall be made in _____ [currency], as follows:</p> <p>(i) Advance Payment: Ten percent (10%) of the Contract Price shall be paid within thirty (30) days of signing of the Contract against a simple receipt and an advance payment guarantee for the equivalent amount and in the form</p>



	<p>provided in the Bidding Documents.</p> <p>(ii) On Delivery: Eighty percent (80%) of the Contract Price shall be paid on receipt of the Goods and upon submission of the documents specified in GCC Clause 13.</p> <p>(iii) On Acceptance: The remaining ten percent (10%) of the Contract Price shall be paid to the Supplier within thirty (30) days after the date of the acceptance certificate for the respective delivery issued by the Purchaser.</p>
GCC 17.5	<p>The payment delay period after which the Purchaser shall pay interest to the supplier shall be <i>[60]</i> days.</p> <p>The interest rate that shall be applied is <i>[12]</i> %</p>
GCC 19.1	<p>The amount of the Performance Security shall be: <i>10 % of contract price and currency shall be same as the currency of payment</i></p> <p><i>[The amount of the Performance Security is usually expressed as a percentage of the Contract Price. The percentage varies according to the Purchaser's perceived risk and impact of non-performance by the Supplier. A figure of ten percent (10%) is used under normal circumstances]</i></p>
GCC 19.3	<p>The types of acceptable Performance Securities are:</p> <p>(i) <u>Unconditional bank guarantee issued by a reputable financial institution acceptable to the Purchaser, in the form provided for in the Contract or in any other form acceptable to the Purchaser, or</u></p> <p>(ii) Cash warrant, or</p> <p>(iii) Demand draft.</p>
GCC 19.4	Discharge of Performance Security shall take place: <i>Same as clause 19.4 of GCC</i>
GCC 24.2	The packing, marking and documentation within and outside the packages shall be: <i>As indicated in Instruction to Bidders</i>
GCC 25.1	<p>The insurance coverage shall be <u>as specified in the Incoterms.</u></p> <p>If not in accordance with Incoterms, insurance shall be as follows:</p> <p><i>Any expenses incurred for the insurance of the goods during transactions are to be paid by the supplier</i></p>
GCC 26.1	Responsibility for transportation of the Goods shall be <u>as specified in the Incoterms.</u> <i>(20015, DAP) plus transportation insurance</i>



	If not in accordance with Incoterms, responsibility for transportation shall be as follows: <i>All the transport expenses till the destination as specified should be at the cost of suppliers</i>
GCC 27.1	The inspections and tests shall be: carried out within two weeks from the date of items received.
GCC 27.2	Inspections and tests shall be conducted at: <i>College of Science and Technology, Kharbandhi, Phuentsholing, Bhutan</i>
GCC 28.1	The liquidated damages shall be: <i>0.7%</i> per week.
GCC 28.1	The maximum amount of liquidated damages shall be: <i>10 %</i> .
GCC 29.3	The period of validity of the Warranty shall be: <u><i>365 days</i></u> . <u>For the purposes of the Warranty the place(s) of final destination(s) shall be: <i>College of Science and Technology, Kharbandhi, Phuentsholing, P.Box #450, Bhutan</i></u>
GCC 29.5 and 29.6	The period for repair or replacement shall be: <i>[30]</i> days.



Attachment: Price Adjustment Formula

If, in accordance with GCC 16.2, prices shall be adjustable, the following method shall be used to calculate the price adjustment:

- 16.2 Prices payable to the Supplier, as stated in the Contract, shall be subject to adjustment during performance of the Contract to reflect changes in the cost of labor and material components in accordance with the formula:

$$P_1 = P_0 \left[a + \frac{bL_1}{L_0} + \frac{cM_1}{M_0} \right] - P_0$$

$$a+b+c = 1$$

in which:

- P_1 = adjustment amount payable to the Supplier.
 P_0 = Contract Price (base price).
 a = fixed element representing profits and overheads included in the Contract Price and generally in the range of five (5) to fifteen percent (15%).
 b = estimated percentage of labor component in the Contract Price.
 c = estimated percentage of material component in the Contract Price.
 L_0, L_1 = labor indices applicable to the appropriate industry in the country of origin on the base date and date for adjustment, respectively.
 M_0, M_1 = material indices for the major raw material on the base date and date for adjustment, respectively, in the country of origin.

The coefficients a , b , and c as specified by the Purchaser are as follows:

- $a = [insert\ value\ of\ coefficient]$
 $b = [insert\ value\ of\ coefficient]$
 $c = [insert\ value\ of\ coefficient]$

The Bidder shall indicate the source of the indices and the base date indices in its bid.

Base date = thirty (30) days prior to the deadline for submission of the bids.

Date of adjustment = $[insert\ number\ of\ weeks]$ weeks prior to date of shipment (representing the mid-point of the period of manufacture).

The above price adjustment formula shall be invoked by either party subject to the following further conditions:

- (a) No price adjustment shall be allowed beyond the original delivery dates unless specifically stated in the extension letter. As a rule, no price adjustment shall be allowed for periods of delay for which the Supplier is entirely responsible. The Purchaser will, however, be entitled to any decrease in the prices of the Goods and Services subject to adjustment.



- (b) If the currency in which the Contract Price P_0 is expressed is different from the currency of origin of the labor and material indices, a correction factor will be applied to avoid incorrect adjustments of the Contract Price. The correction factor shall correspond to the ratio of exchange rates between the two currencies on the base date and the date for adjustment as defined above.
- (c) No price adjustment shall be payable on the portion of the Contract Price paid to the Supplier as advance payment.



Section IX. Contract Forms

Table of Forms

Contract Agreement..... 76

Performance Security 78

Bank Guarantee for Advance Payment 79



Contract Agreement

THIS CONTRACT AGREEMENT made on the _____ day of _____ month, 2018,

BETWEEN

- (1) *College of Science and Technology, an agency of Royal University of Bhutan of the Government of Bhutan under the laws of Bhutan and having its principal place of business at Richending, Phuentsholing (hereinafter called “the Purchaser”), and*
- (2) _____, a corporation incorporated under the laws of Bhutan and having its principal place of business at _____ (hereinafter called “the Supplier”).

WHEREAS the Purchaser invited Bids for certain Goods and ancillary services for _____ and has accepted a Bid by the Supplier for the supply of those Goods and Services (as per the purchase order) in the sum of _____ [insert Contract Price in words and figures, expressed in the Contract currency/ies] (hereinafter called “the Contract Price”).

NOW THIS AGREEMENT WITNESSETH AS FOLLOWS:

1. In this Agreement words and expressions shall have the same meanings as are respectively assigned to them in the Conditions of Contract referred to.
2. The following documents shall constitute the Contract between the Purchaser and the Supplier, and each shall be read and construed as an integral part of the Contract, viz.:
 - (a) This Contract Agreement;
 - (b) The Special Conditions of Contract;
 - (c) The General Conditions of Contract;
 - (d) Technical Requirements (including Schedule of Supply and Technical Specifications);
 - (e) The Supplier’s Bid and original Price Schedules;
 - (f) The Purchaser’s Notification of Award of Contract;
 - (g) The form of Performance Security;
 - (h) The form of Bank Guarantee for Advance Payment;



3. This Contract shall prevail over all other Contract documents. In the event of any discrepancy or inconsistency within the Contract documents, then the documents shall prevail in the order listed above.
4. In consideration of the payments to be made by the Purchaser to the Supplier as hereinafter mentioned, the Supplier hereby covenants with the Purchaser to provide the Goods and Services and to remedy defects therein in conformity in all respects with the provisions of the Contract.
5. The Purchaser hereby covenants to pay the Supplier in consideration of the provision of the Goods and Related Services and the remedying of defects therein, the Contract Price or such other sum as may become payable under the provisions of the Contract at the times and in the manner prescribed by the Contract.

IN WITNESS whereof the parties hereto have caused this Agreement to be executed in accordance with the laws of Bhutan on the day, month and year indicated above.

For and on behalf of the Purchaser

Signed: _____

in the capacity of _____ *[insert title or other appropriate designation]*

in the presence of _____

[insert identification of official witness]

For and on behalf of the Supplier

Signed: _____ in the capacity of _____ *[insert title*

or other appropriate designation] in the presence of _____ *[insert*

identification of official witness]



INTEGRITY PACT

1 General:

Whereas (*Name of head of the procuring agency or his/her authorized representative, with power of attorney*) representing the (*College of Science & Technology*), Royal University of Bhutan, hereinafter referred to as the “**Employer**” on one part, and (*Name of bidder or his/her authorized representative, with power of attorney*) representing M/s (*Name of firm*), hereinafter referred to as the “**Bidder**” on the other part hereby execute this agreement as follows:

This agreement shall be a part of the standard bidding document, which shall be signed by both the parties at the time of purchase of bidding documents and submitted along with the tender document. This IP is applicable only to “**large**” scale works, goods and services, the threshold of which will be announced by the government from time to time. The signing of the IP shall not apply to framework contracting such as annual office supplies etc.

2 Objectives:

Whereas, the Employer and the Bidder agree to enter into this agreement, hereinafter referred to as IP, to avoid all forms of corruption or deceptive practice by following a system that is fair, transparent and free from any influence/unprejudiced dealings in the **bidding process**¹³ and **contract administration**¹⁴, with a view to:

- 2.1 Enabling the Employer to obtain the desired contract at a reasonable and competitive price in conformity to the defined specifications of the works or goods or services; and
- 2.2 Enabling bidders to abstain from bribing or any corrupt practice in order to secure the contract by providing assurance to them that their competitors will also refrain from bribing and other corrupt practices.

3. Scope:

The validity of this IP shall cover the bidding process and contract administration period.

4. Commitments of the Employer:

The Employer Commits itself to the following:-

¹³ Bidding process, for the purpose of this IP, shall mean the procedures covering tendering process starting from bid preparation, bid submission, bid processing, and bid evaluation.

¹⁴ Contract administration, for the purpose of this IP, shall mean contract award, contract implementation, unauthorized sub-contracting and contract handing/taking over.



- 4.1 The Employer hereby undertakes that no officials of the Employer, connected directly or indirectly with the contract, will demand, take a promise for or accept, directly or through intermediaries, any bribe, consideration, gift, reward, favor or any material or immaterial benefit or any other advantage from the Bidder, either for themselves or for any person, organization or third party related to the contract in exchange for an advantage in the bidding process and contract administration.
- 4.2 The Employer further confirms that its officials shall not favor any prospective bidder in any form that could afford an undue advantage to that particular bidder in the bidding process and contract administration and will treat all Bidders alike.
- 4.3 Officials of the Employer, who may have observed or noticed or have reasonable suspicion shall report to the head of the employing agency or an appropriate government office any violation or attempted violation of clauses 4.1 and 4.2.
- 4.4 Following report on violation of clauses 4.1 and 4.2 by official (s), through any source, necessary disciplinary proceedings, or any other action as deemed fit, including criminal proceedings shall be initiated by the Employer and such a person shall be debarred from further dealings related to the bidding process and contract administration.

5. Commitments of Bidders

The Bidder commits himself/herself to take all measures necessary to prevent corrupt practices, unfair means and illegal activities during any stage of the bidding process and contract administration in order to secure the contract or in furtherance to secure it and in particular commits himself/herself to the following :-

- 5.1 The Bidder shall not offer, directly or through intermediaries, any bribe, gift, consideration, reward, favor, any material or immaterial benefit or other advantage, commission, fees, brokerage or inducement to any official of the Employer, connected directly or indirectly with the bidding process and contract administration, or to any person, organization or third party related to the contract in exchange for any advantage in the bidding process and contract administration.
- 5.2 The Bidder shall not collude with other parties interested in the contract to manipulate in whatsoever form or manner, the bidding process and contract administration.
- 5.3 If the bidder(s) have observed or noticed or have reasonable suspicion that the provisions of the IP have been violated by the procuring agency or other bidders, the bidder shall report such violations to the head of the procuring agency.

6. Sanctions for Violation:



The breach of any of the aforesaid provisions shall result in administrative charges or penal actions as per the relevant rules and laws.

6.1 The breach of the IP or commission of any offence (forgery, providing false information, mis-representation, providing false/fake documents, bid rigging, bid steering or coercion) by the Bidder, or any one employed by him, or acting on his/her behalf (whether with or without the knowledge of the Bidder), shall be dealt with as per the terms and conditions of the contract and other provisions of the relevant laws, including De-barment Rules.

6.2 The breach of the IP or commission of any offence by the officials of the procuring agency shall be dealt with as per the rules and laws of the land in vogue.

7. Monitoring and Administration:

7.1 The respective procuring agency shall be responsible for administration and monitoring of the IP as per the relevant laws.

7.2 The bidder shall have the right to appeal as per the arbitration mechanism contained in the relevant rules.

We, hereby declare that we have read and understood the clauses of this agreement and shall abide by it.

The parties hereby sign this Integrity Pact at (place) _____ on (date) _____

Affix
Legal
Stamp

Affix
Legal
Stamp

EMPLOYER

BIDDER/REPRESENTATIVE

CID :

CID :

Witness: _____

Witness: _____

Name:

Name:

CID :

CID :



Performance Security

[The bank, as requested by the successful Bidder, shall fill in this form in accordance with the instructions indicated]

Date: *[insert date (as day, month, and year) of Bid submission]*
IFB No. and title: *[insert no. and title of bidding process]*

Bank's Branch or Office: *[insert complete name of Guarantor]*

Beneficiary: *[insert complete name of Purchaser]*

PERFORMANCE GUARANTEE No.: *[insert Performance Guarantee number]*

We have been informed that *[insert complete name of Supplier]* (hereinafter called "the Supplier") has entered into Contract No. *[insert number]* dated *[insert day and month]*, *[insert year]* with you, for the supply of *[description of Goods and related Services]* (hereinafter called "the Contract").

Furthermore, we understand that, according to the conditions of the Contract, a Performance Guarantee is required.

At the request of the Supplier, we hereby irrevocably undertake to pay you any sum(s) not exceeding *[insert amount(s)]*¹⁵ *in figures and words* upon receipt by us of your first demand in writing declaring the Supplier to be in default under the Contract, without cavil or argument, or you needing to prove or to show grounds or reasons for your demand or the sum specified therein.

This Guarantee shall expire no later than the *[insert number]* day of *[insert month]* *[insert year]*,¹⁶ and any demand for payment under it must be received by us at this office on or before that date. We agree to a one-time extension of this Guarantee for a period not to exceed *[six months]* *[one year]*, in response to the Purchaser's written request for such extension, such request to be presented to us before the expiry of the Guarantee.

[signatures of authorized representatives of the bank and the Supplier]

¹⁵ The Bank shall insert the amount(s) specified in the SCC and denominated, as specified in the SCC, either in the currency(ies) of the Contract or a freely convertible currency acceptable to the Purchaser.

¹⁶ Date established in accordance with Clause 19.4 of the General Conditions of Contract ("GCC"). The Purchaser should note that in the event of an extension of the time to perform the Contract, the Purchaser would need to request an extension of this Guarantee from the Bank. Such request must be in writing and must be made prior to the expiration date established in the Guarantee.



Bank Guarantee for Advance Payment

[The bank, as requested by the successful Bidder, shall fill in this form in accordance with the instructions indicated.]

Date: *[insert date (as day, month, and year) of Bid submission]*

IFB No. and title: *[insert number and title of bidding process]*

[bank's letterhead]

Beneficiary: *[insert legal name and address of Purchaser]*

ADVANCE PAYMENT GUARANTEE No.: *[insert Advance Payment Guarantee no.]*

We, *[insert legal name and address of bank]*, have been informed that *[insert complete name and address of Supplier]* (hereinafter called "the Supplier") has entered into Contract No. *[insert number]* dated *[insert date of Contract]* with you, for the supply of *[insert types of Goods to be delivered]* (hereinafter called "the Contract").

Furthermore, we understand that, according to the conditions of the Contract, an advance payment is to be made against an advance payment guarantee.

At the request of the Supplier, we hereby irrevocably undertake to pay you any sum or sums not exceeding in total an amount of *[insert amount(s)]¹⁷ in figures and words* upon receipt by us of your first demand in writing declaring that the Supplier is in breach of its obligation under the Contract because the Supplier used the advance payment for purposes other than toward delivery of the Goods.

It is a condition for any claim and payment under this Guarantee to be made that the advance payment referred to above must have been received by the Supplier in its account *[insert number and domicile of the account]*

This Guarantee shall remain valid and in full effect from the date of the advance payment received by the Supplier under the Contract until *[insert date]¹⁸*. We agree to a one-time extension of this Guarantee for a period not to exceed *[six months][one year]*, in response to the Purchaser's written request for such extension, such request to be presented to us before the expiry of the Guarantee.

[signature(s) of authorized representative(s) of the bank]

¹⁷ The bank shall insert the amount(s) specified in the SCC and denominated, as specified in the SCC, either in the currency(ies) of the Contract or a freely convertible currency acceptable to the Purchaser.

¹⁸ Insert the Delivery date stipulated in the Contract Delivery Schedule. The Purchaser should note that in the event of an extension of the time to perform the Contract, the Purchaser would need to request an extension of this Guarantee from the bank. Such request must be in writing and must be made prior to the expiration date established in the Guarantee



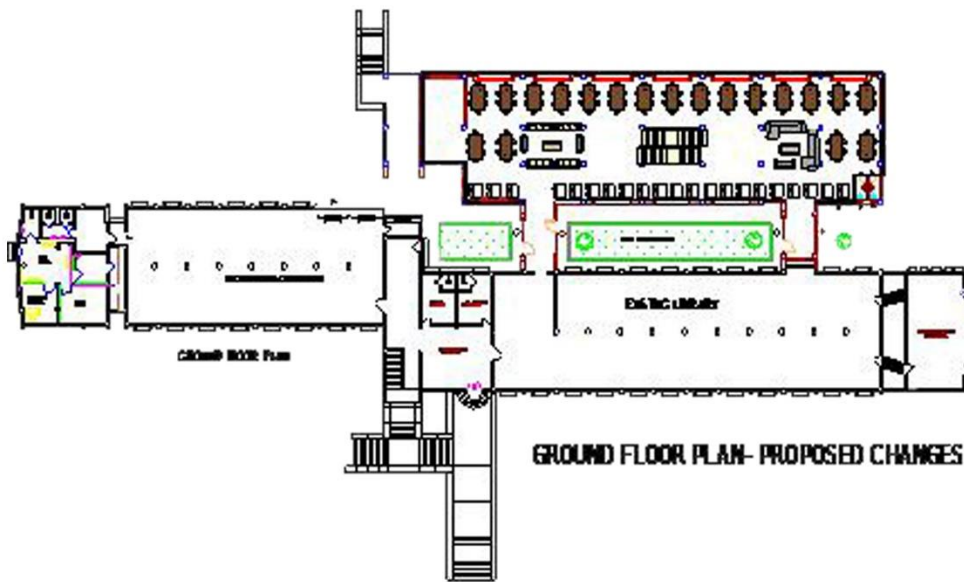
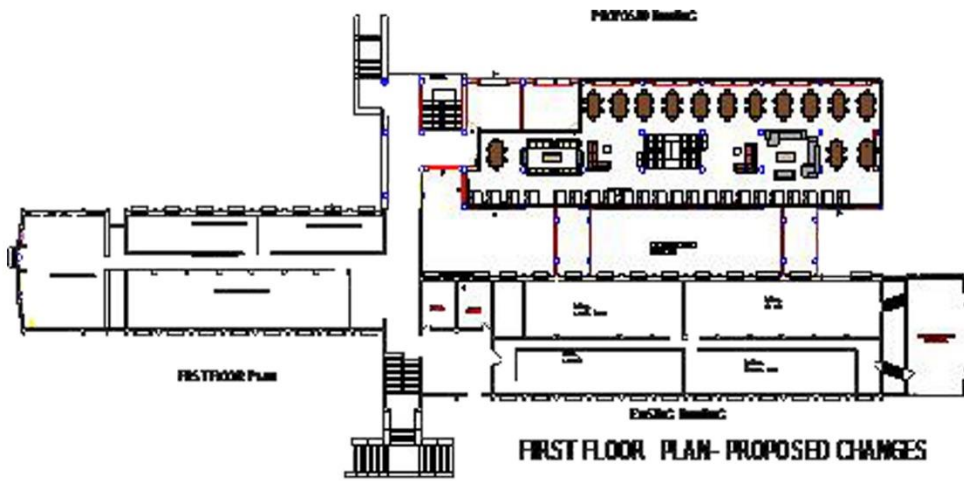

PLAN OF THE LIBRARY

Figure - 1



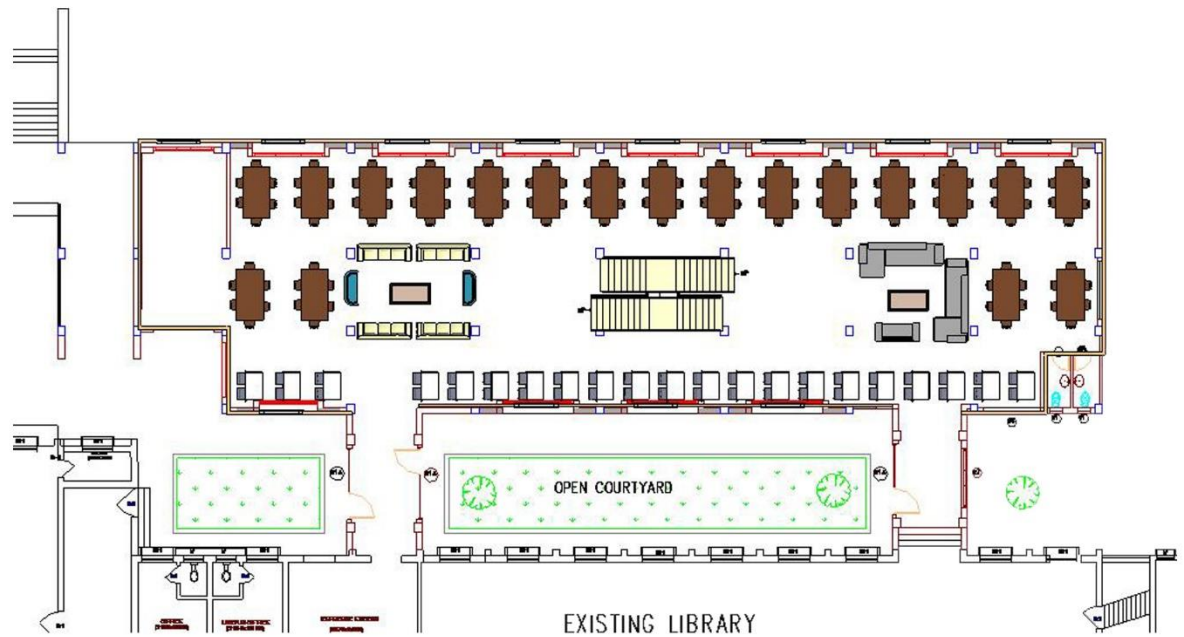

GROUND FLOOR

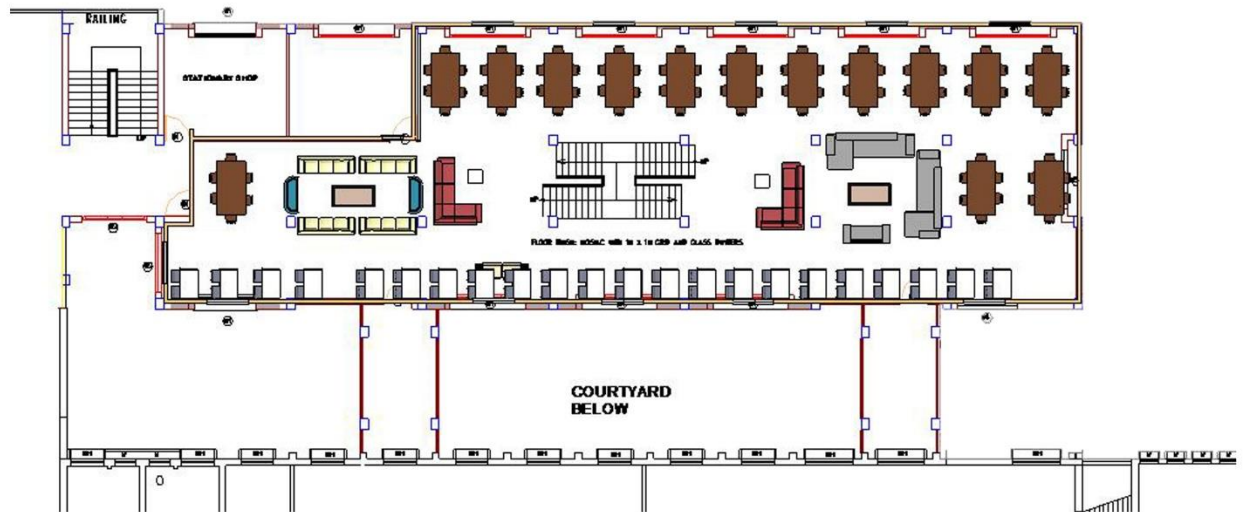

FIRST FLOOR

Figure - 2



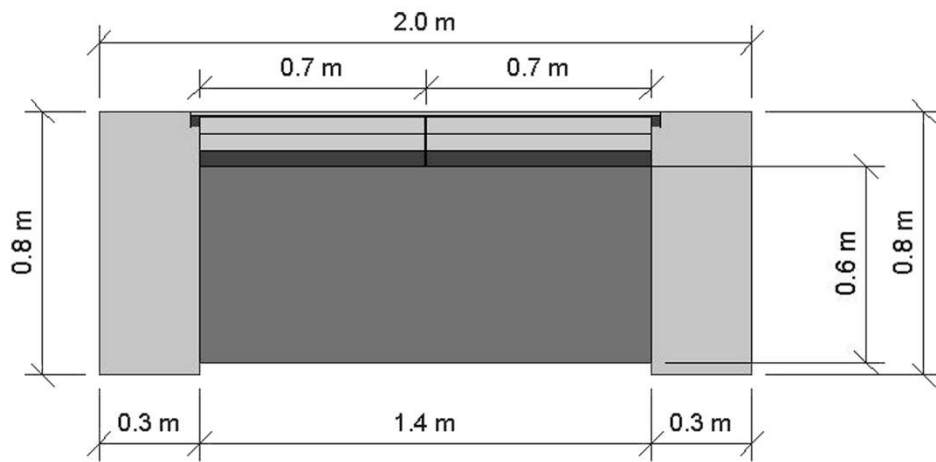

PLAN

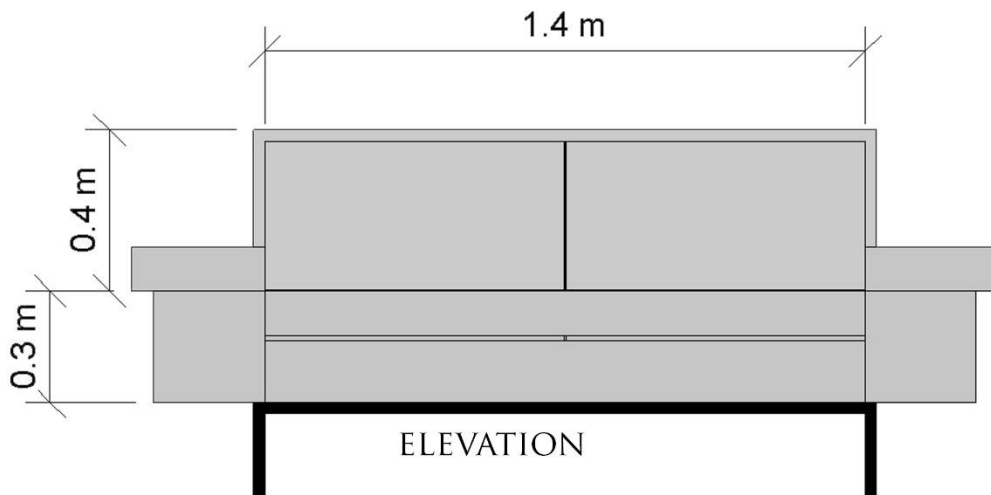

ELEVATION

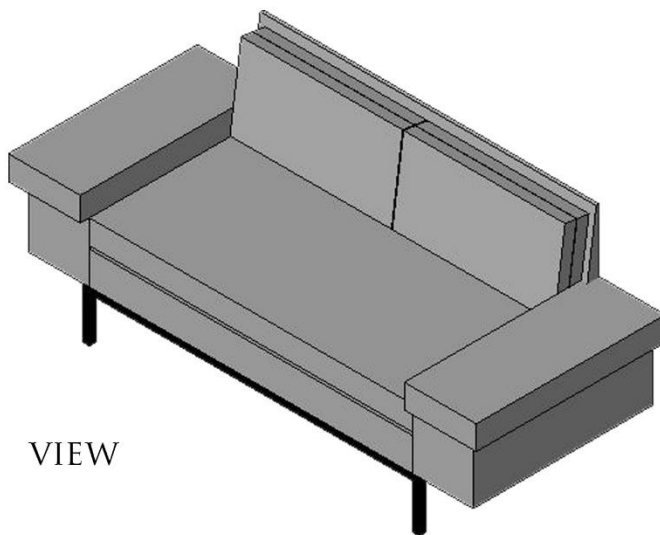

VIEW

PARTICULARS - 2 SEATER
SOFA
QUANTITY- 2 NUMBERS



Figure -3

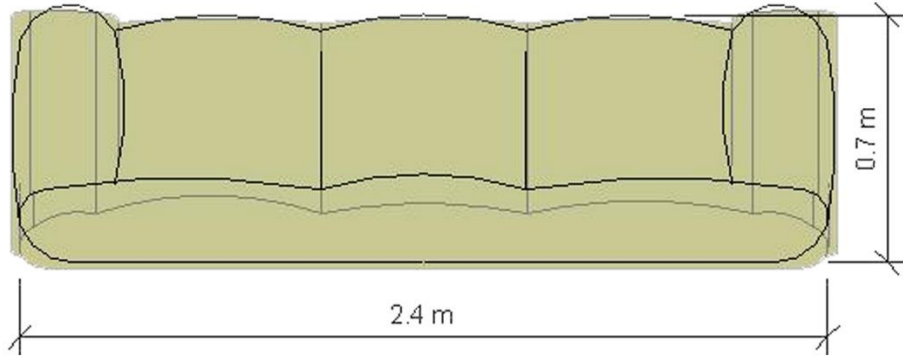

PLAN

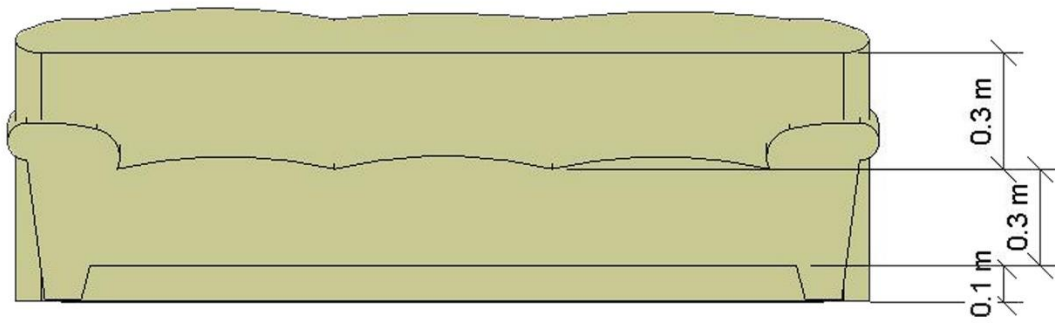

ELEVATION

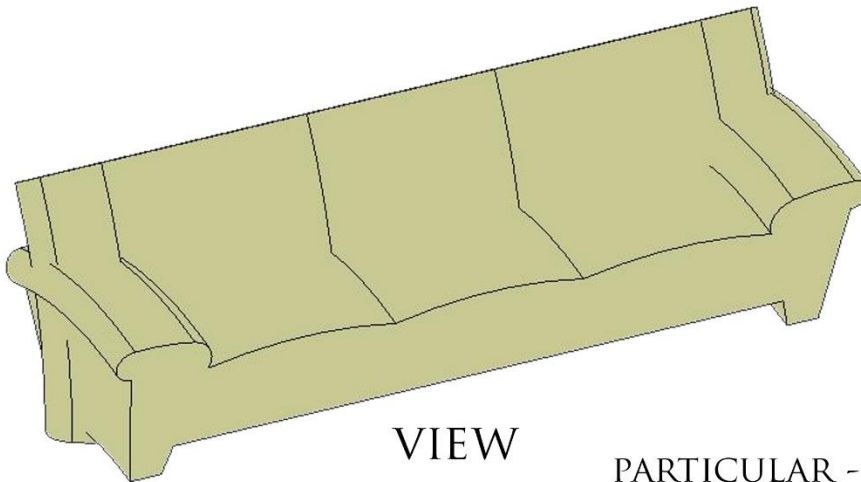

VIEW

PARTICULAR - ARCH SOFA
QUANTITY- 8 NUMBERS

Figure - 4



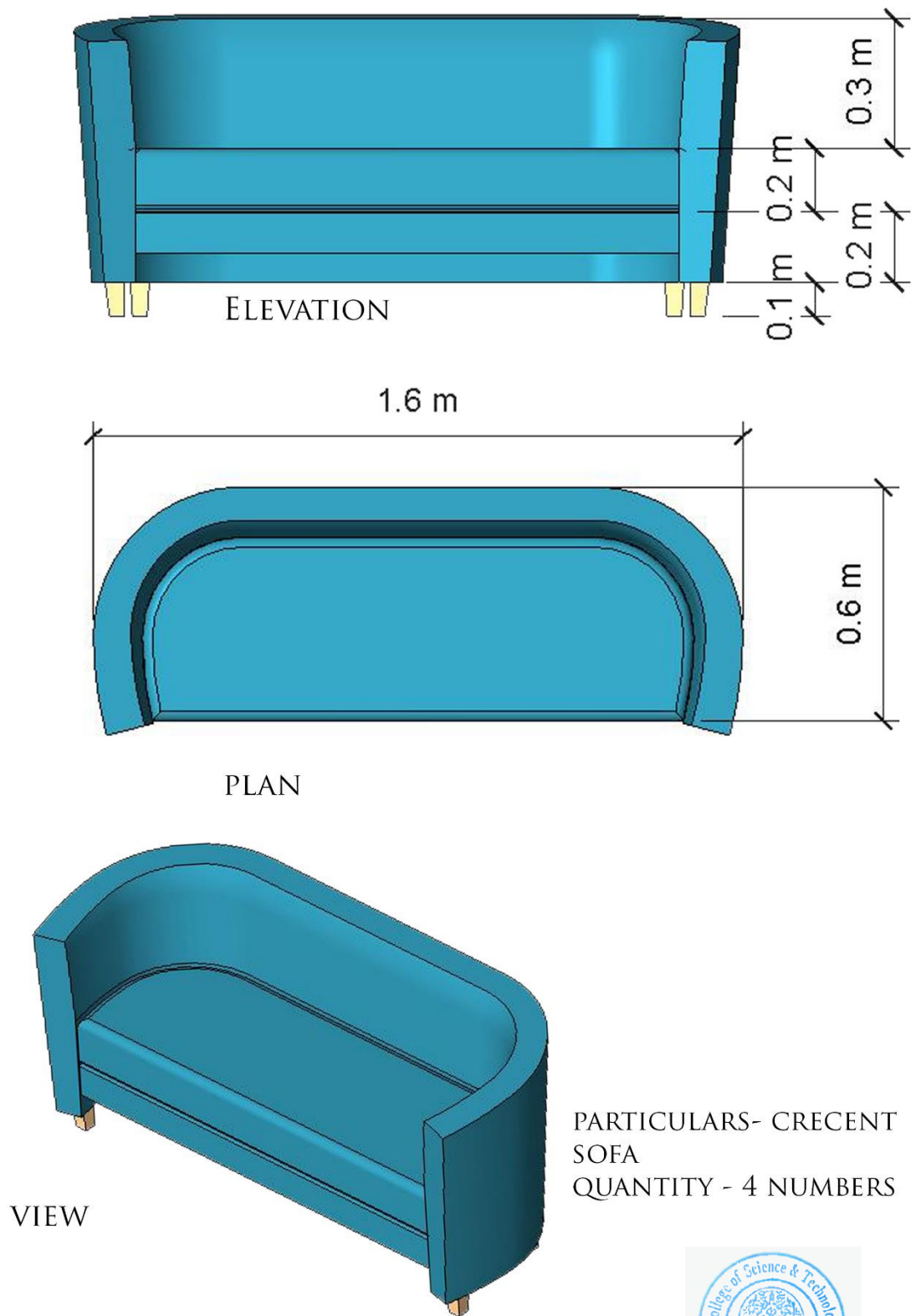
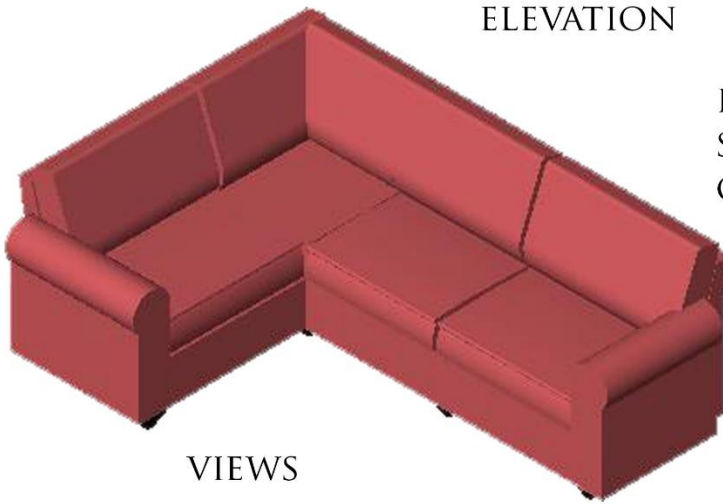
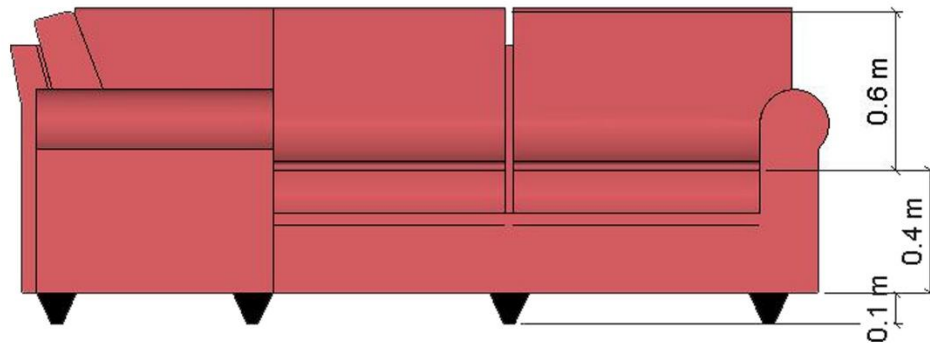
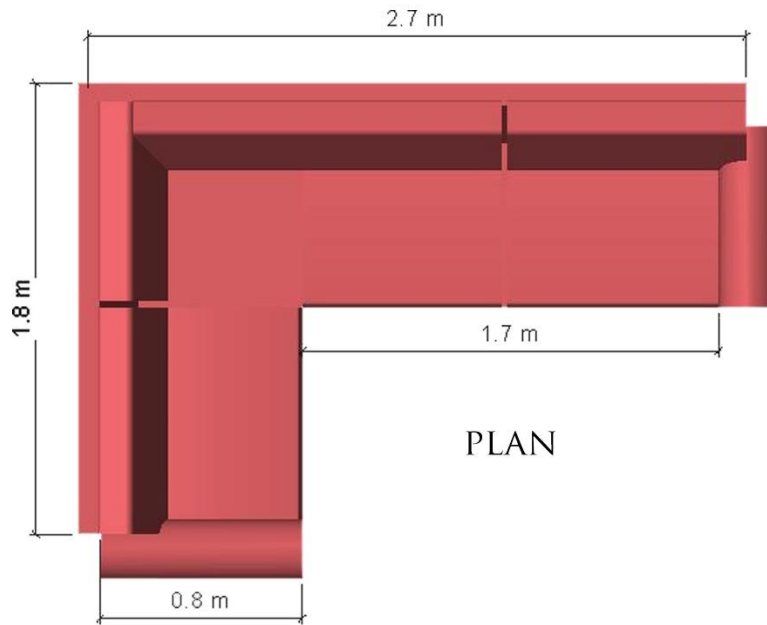

Figure - 5



PARTICULARS- SECTIONAL
SOFA
QUANTITY - 2 NUMBERS

Figure - 6



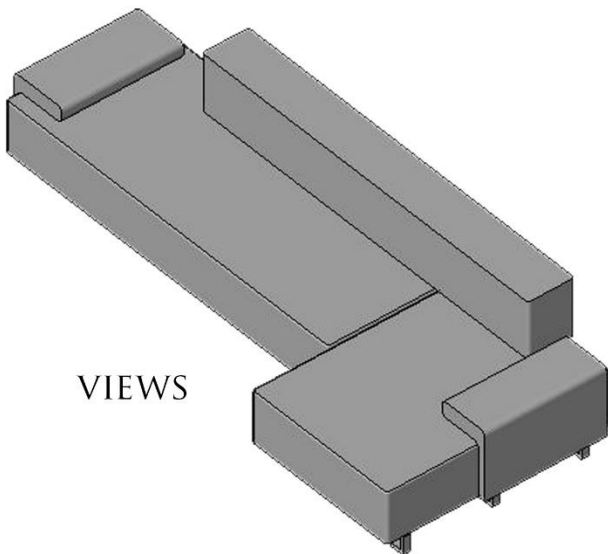
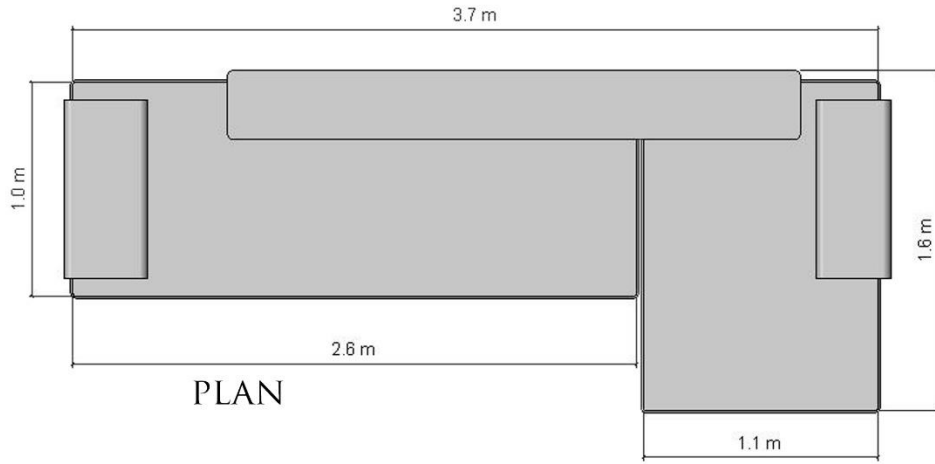

PARTICULARS- SOFA WITH ISLAND
QUANTITY- 4 NUMBERS



Figure - 7

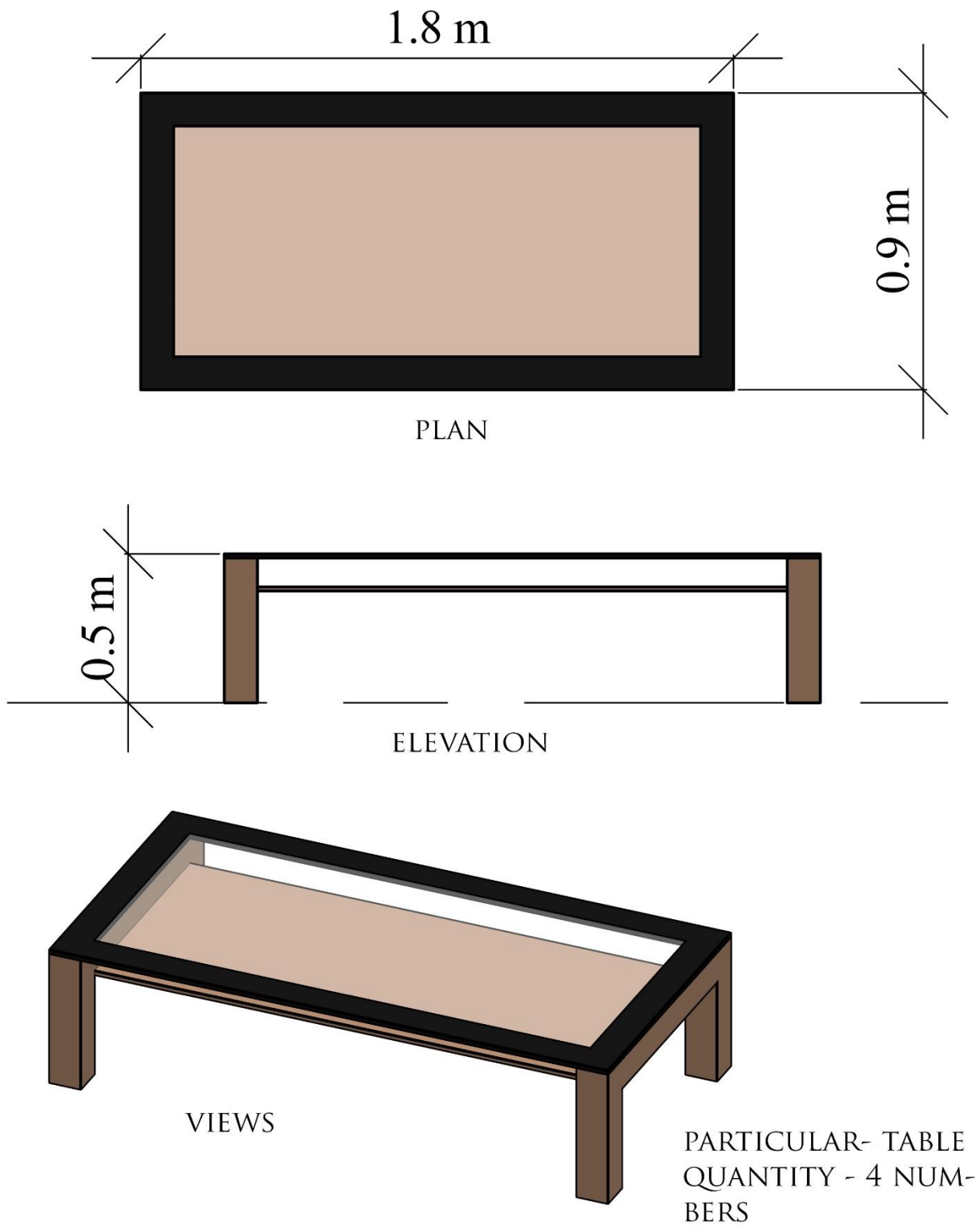
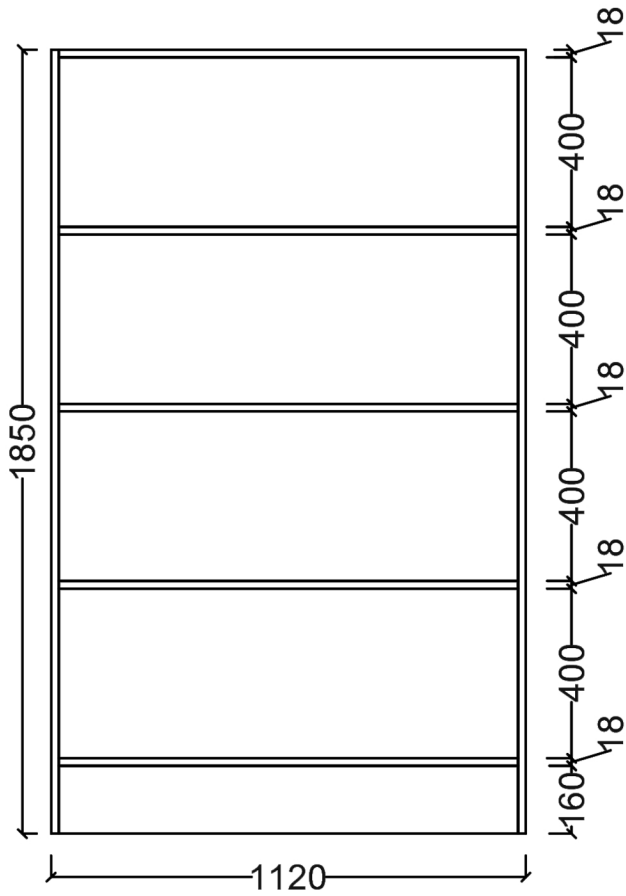
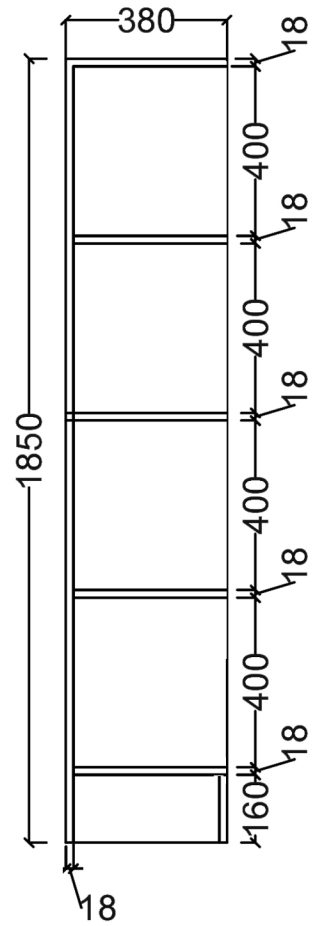

Figure - 8





ELEVATION



SECTION

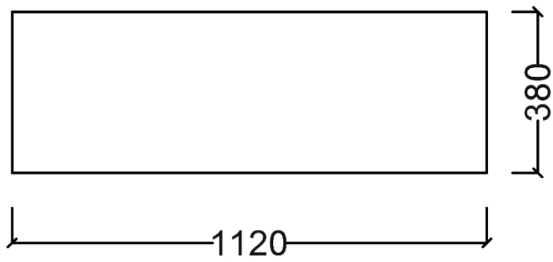

PLAN

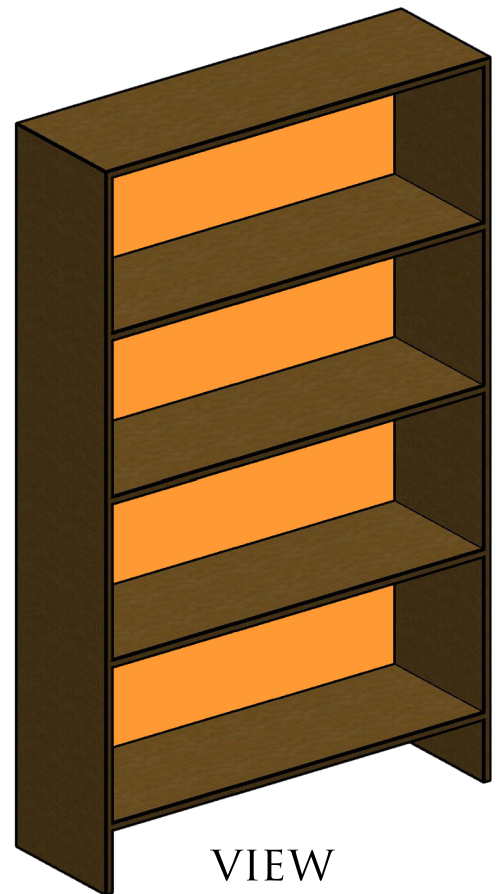

VIEW

BOOK RACK

Figure - 9